

Installation Guide for UBio-X Face V1.0

Walk Through Face Recognition Terminal



Distributed by

genie

Doc Ver1.0

January.,25.2021

R&D Center

Union Community Co., Ltd.

1. The maximum cable length & thickness for installation

1) Using 15V 4A Power Supply & AWG24



15V 4A Adapter

AWG24 10m



AWG24 10m

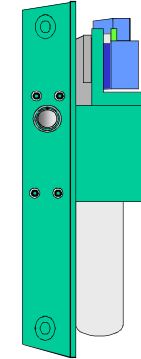

Dead-Bolt
BEHOST BHL-700C
(Standby:0.15A, Start:0.9A)

2) Using 15V 4A Power Supply & AWG22



15V 4A Adapter

AWG22 20m



AWG22 10m

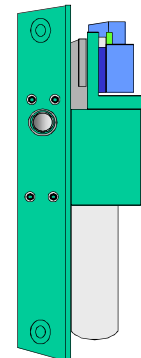

Dead-Bolt
BEHOST BHL-700C
(Standby:0.15A, Start:0.9A)

* Caution: The above data are the measured values when using the adapters and the dead-bolts provided by the Union Community.

1. The maximum cable length & thickness for installation

1) Using 15V 4A Power Supply & AWG20



15V 4A Adapter

AWG20 40m



AWG20 10m

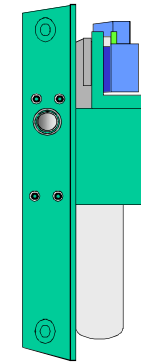

Dead-Bolt
BEHOST BHL-700C
(Standby:0.15A, Start:0.9A)

* Caution: The above data are the measured values when using the adapters and the dead-bolts provided by the Union Community.

2. Description of External Cables

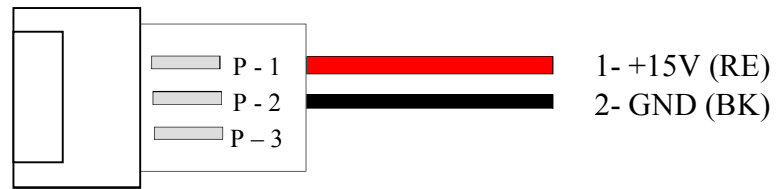

Power Adapter Cable(2P)



Wiegand Cable (5P)



Lock Status Cable (5P)

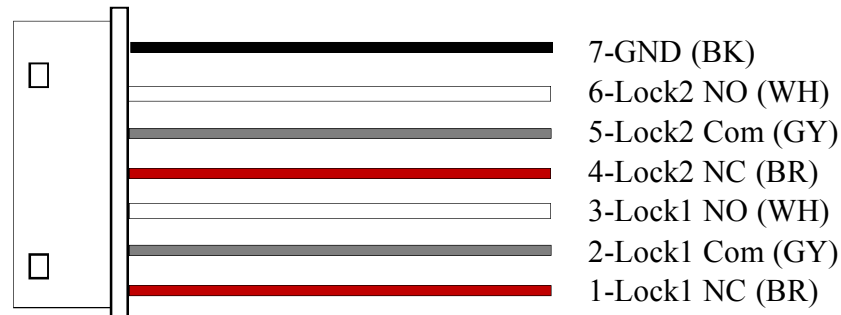

Lock Cable (7P)

2. Description of External Cables

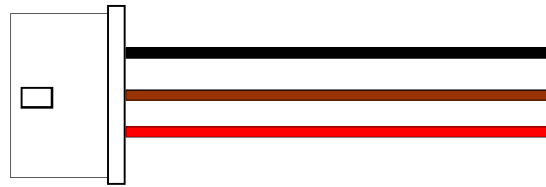

GND (BK) - 3
RXD (BR) - 2
TXD (RE) - 1

RS232 Cable (3P)

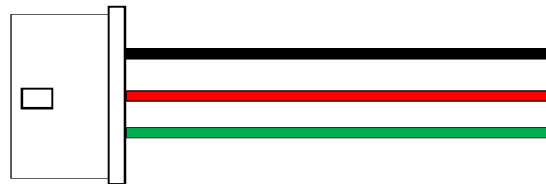

GND (BK) - 3
L_RED (RE) - 2
L_GREEN (GR) - 1

Light Bar Cable (3P)



GND (BK) - 2
5V Out (WH/BK) - 1

5V Out Cable (2P)

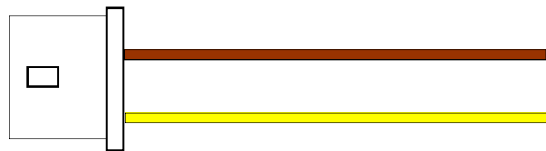

Motor- (BR) - 2
Motor+ (YE) - 1

Motor Cable (2P)

3. Connecting Ethernet (LAN) Cable

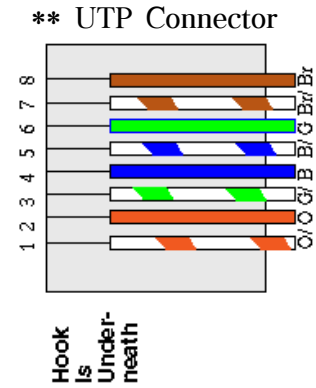
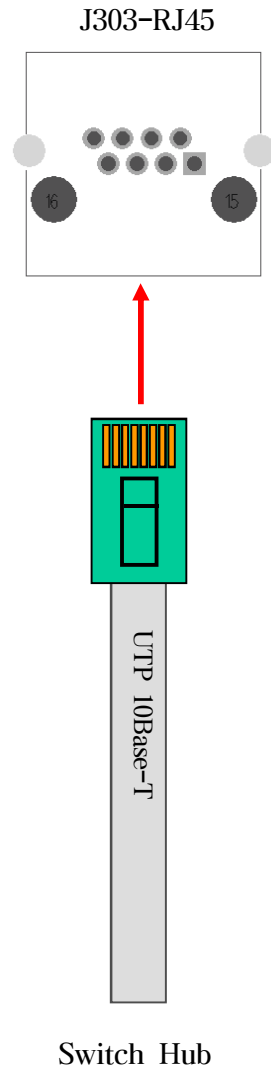

4. Resistor Setting for RS485 End Termination

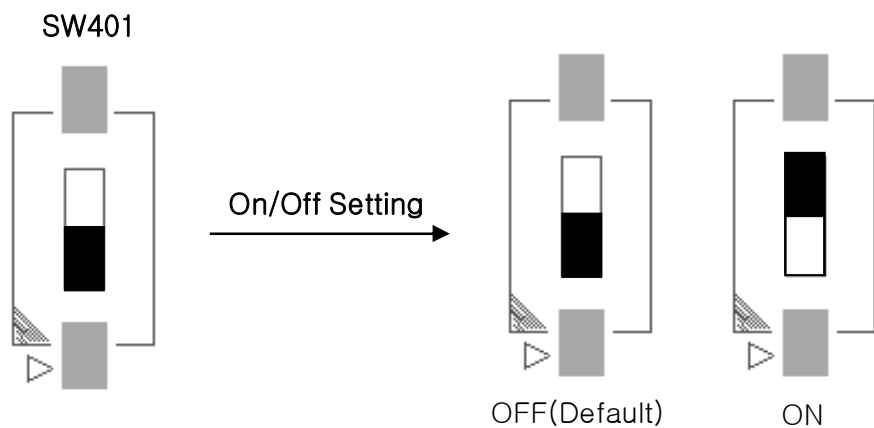
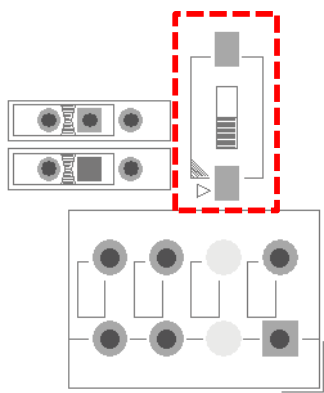

- * Default Setting is off.
- * ON: 120 Ohm Resistor is connected between 485A and 485B

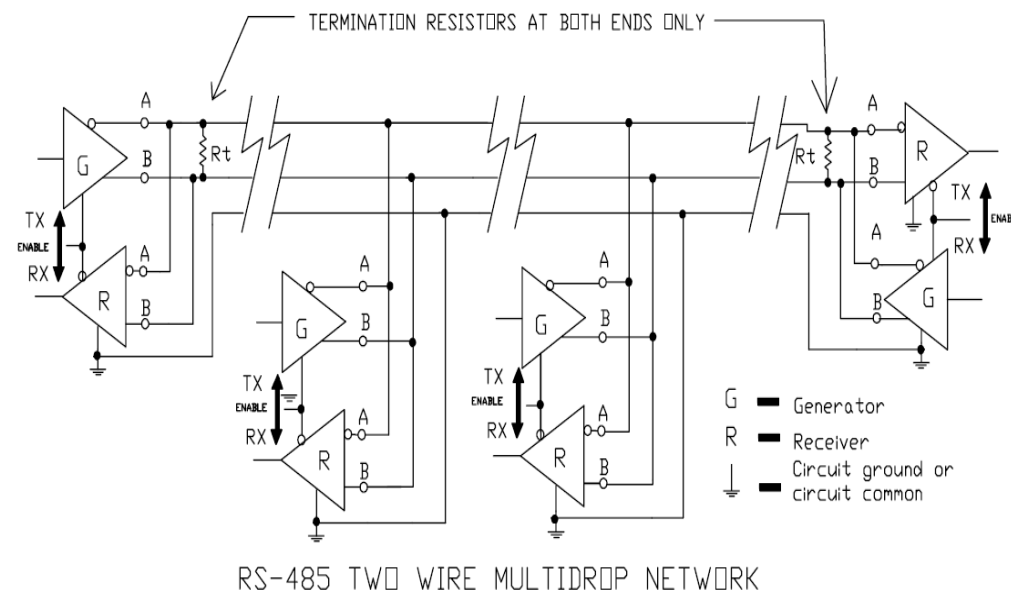

6. Connecting a Dead-Bolt Type Door Lock (Fail Safe)

6.1. Connecting One System/ One Lock



SW551: Power ON

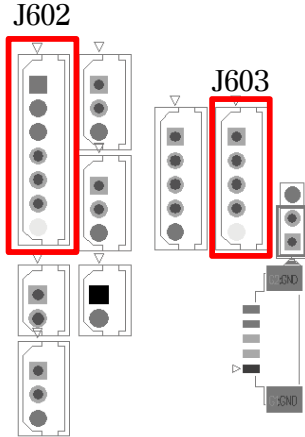

<DB Door Signal>
 Closed: NO-COM, Short
 NC-COM, Open
 Opened: NO-COM, Open
 NC-COM, Short

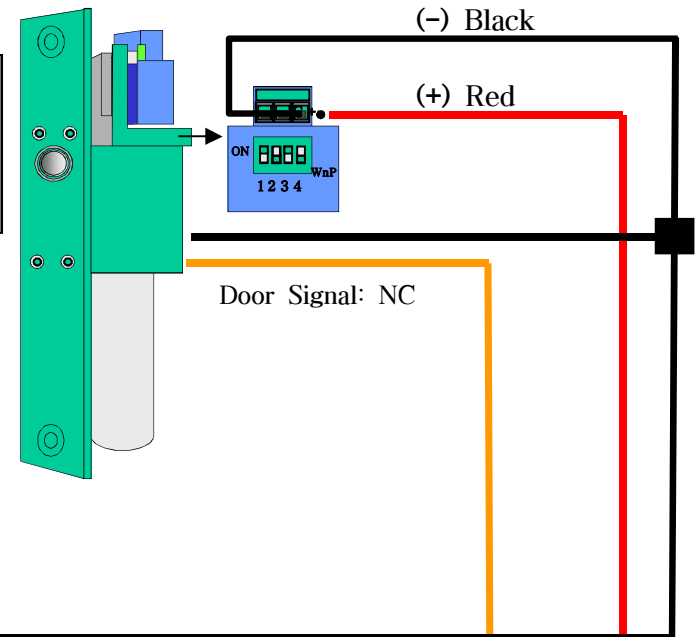

- 7-GND (BK)
- 6-Lock2 NO (WH)
- 5-Lock2 Com (GY)
- 4-Lock2 NC (BR)
- 3-Lock1 NO (WH)
- 2-Lock1 Com (GY)
- 1-Lock1 NC (BR)

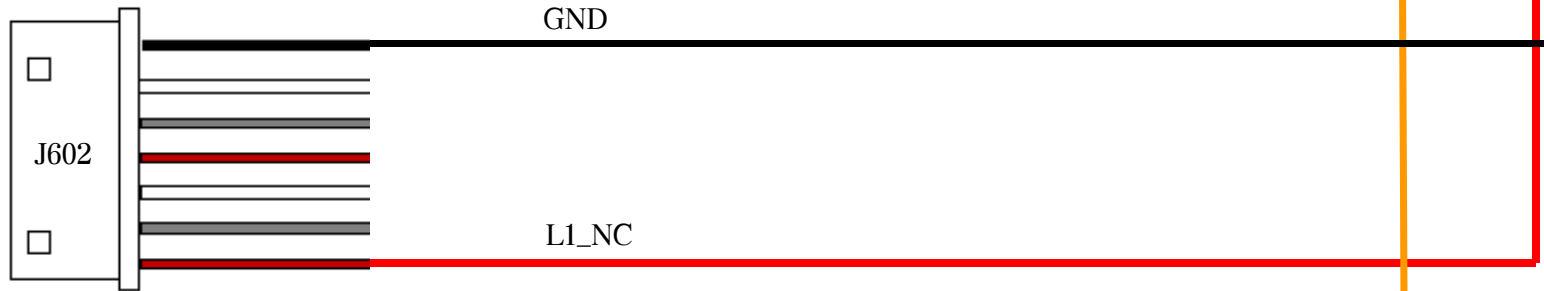

- 5-GND(BK)
- 4-EXITB (OR)
- 3-DM2 (BL)
- 2-DM1 (GR)
- 1-DM0 (YE)

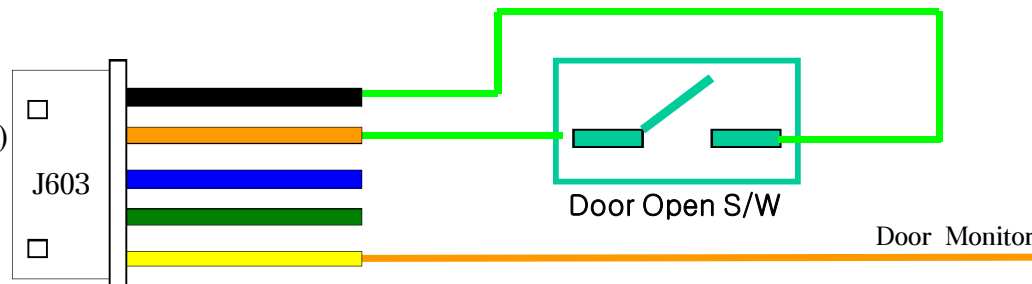

6. Connecting a Dead-Bolt Type Door Lock (Fail Safe)

6.2. Connecting Two Systems/ One Lock

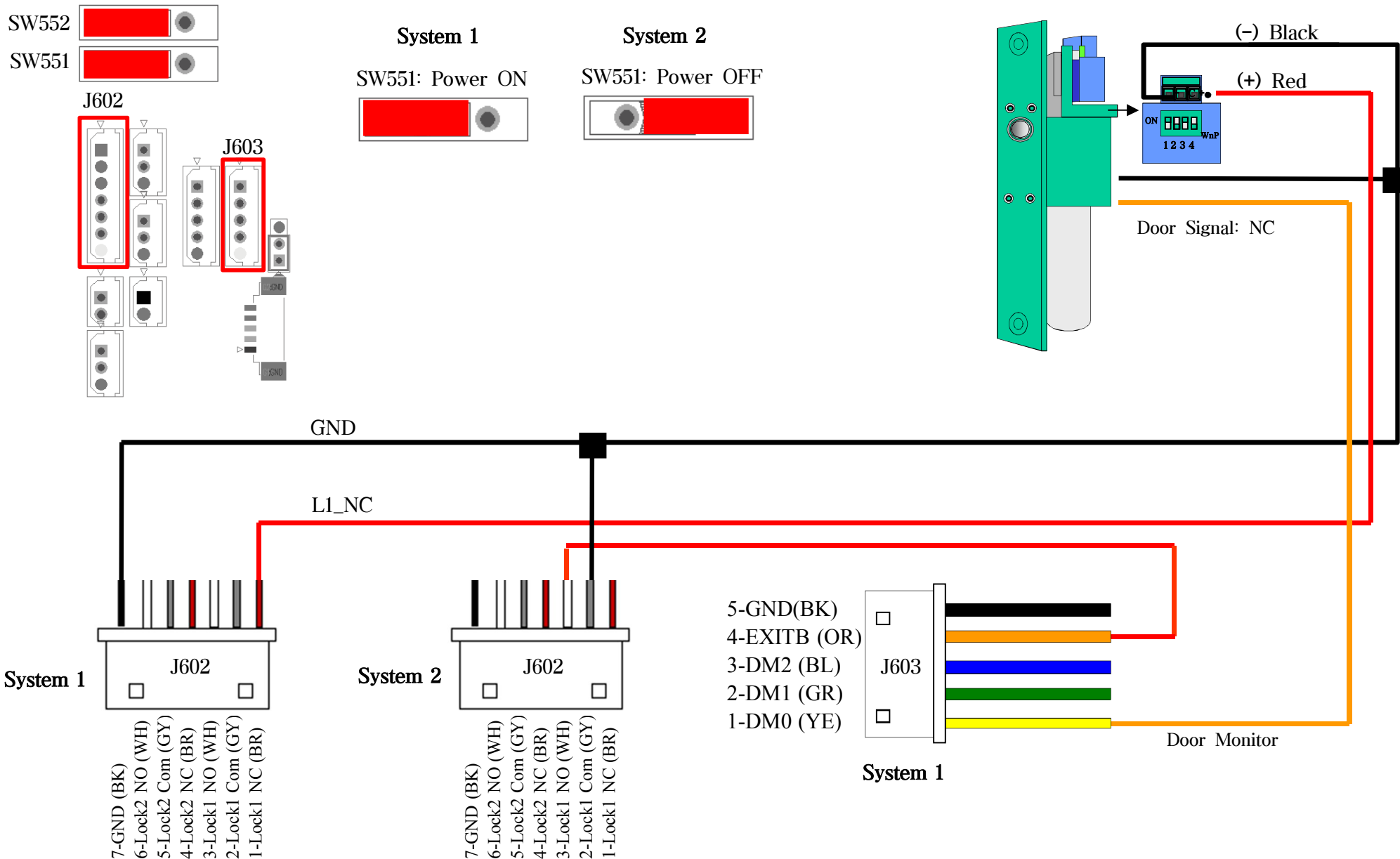

7. Connecting a Strike Type Door Lock (Fail Safe)

7.1. Connecting One System/ One Lock

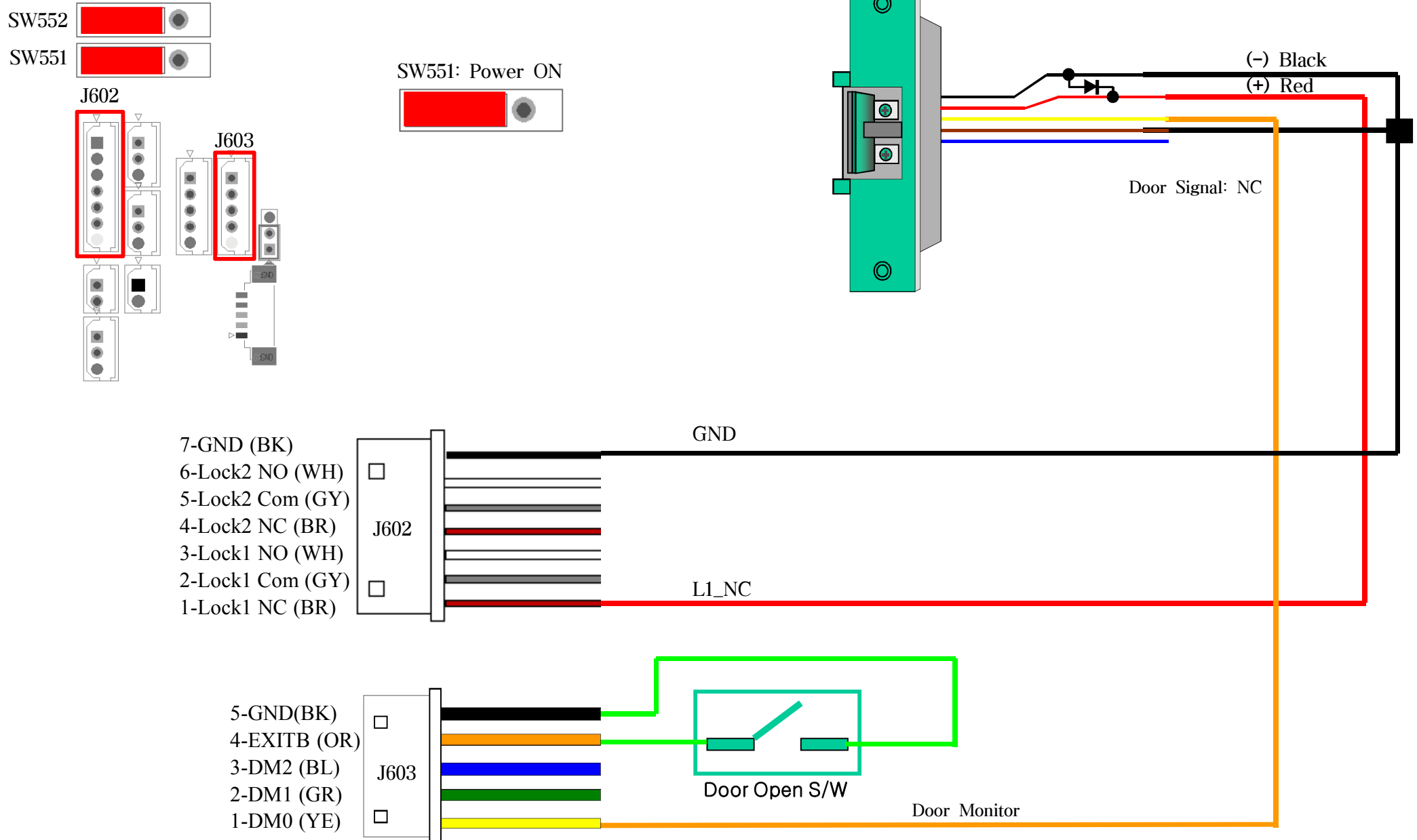

7. Connecting a Strike Type Door Lock (Fail Safe)

7.2. Connecting Two Systems/ One Lock

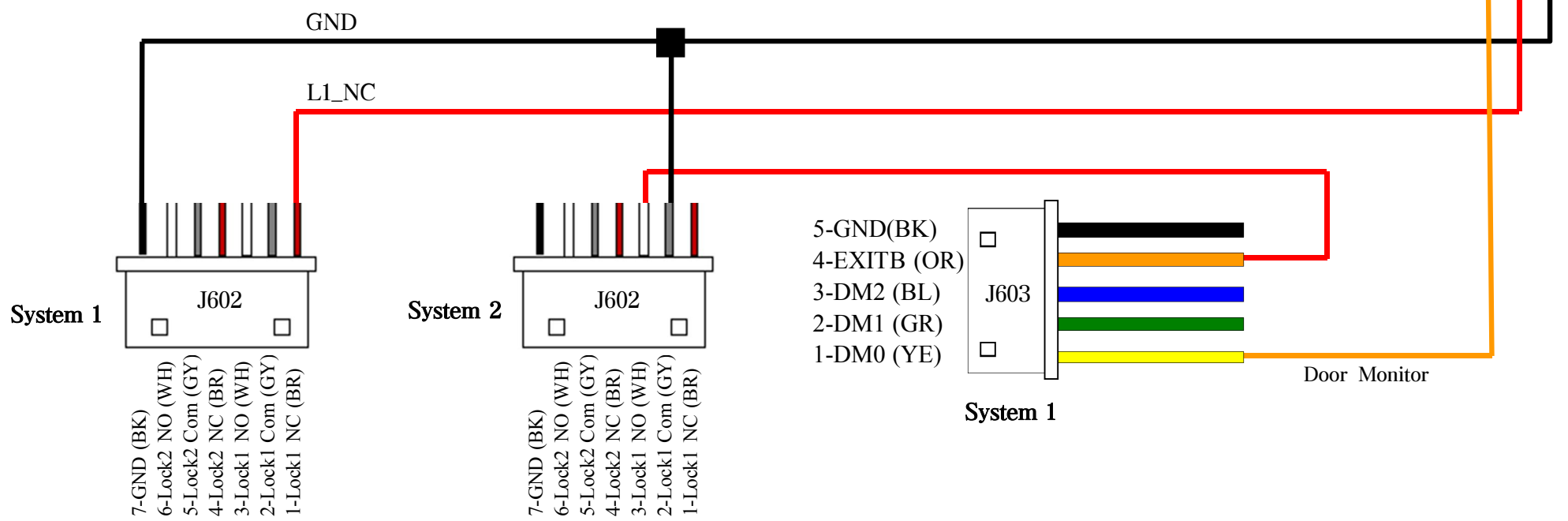
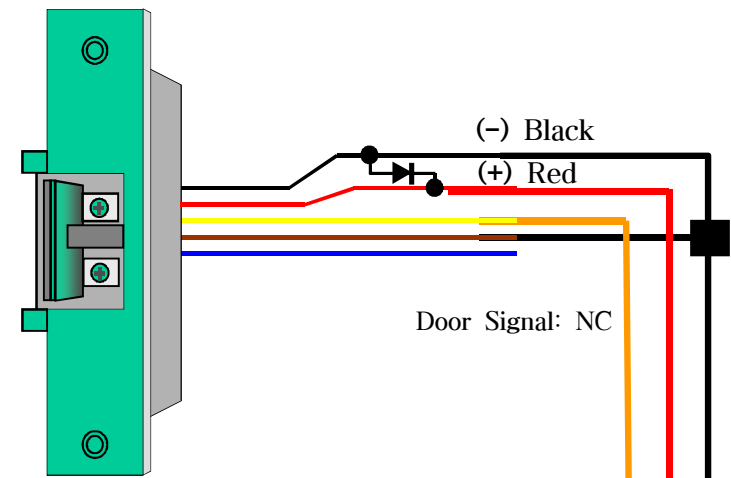
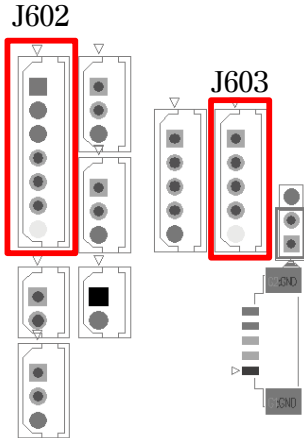

8. Connecting a Strike Type Door Lock (Fail Secure)

8.1. Connecting One System/ One Lock

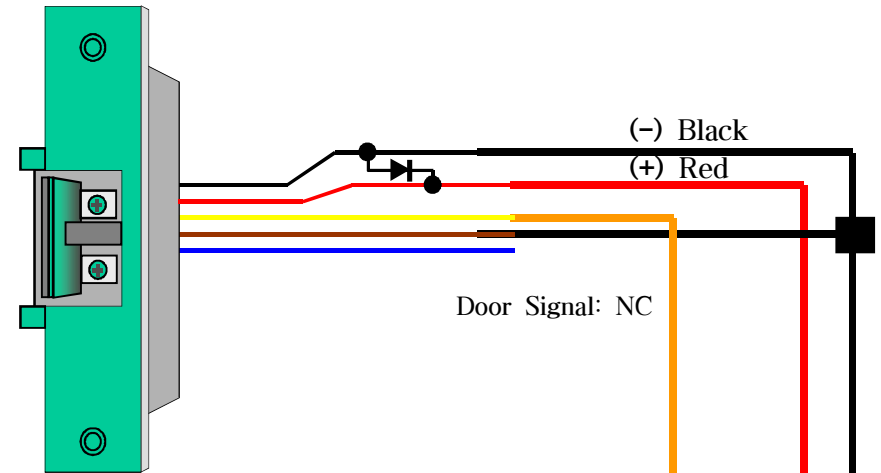
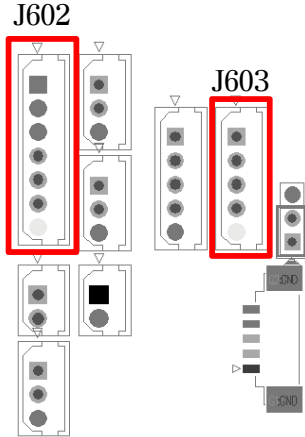
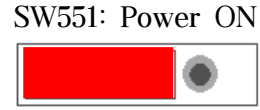

- 7-GND (BK)
- 6-Lock2 NO (WH)
- 5-Lock2 Com (GY)
- 4-Lock2 NC (BR)
- 3-Lock1 NO (WH)
- 2-Lock1 Com (GY)
- 1-Lock1 NC (BR)

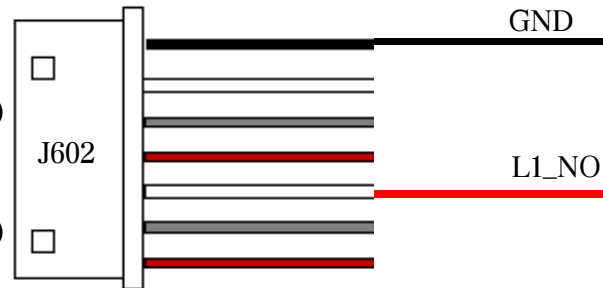

- 5-GND(BK)
- 4-EXITB (OR)
- 3-DM2 (BL)
- 2-DM1 (GR)
- 1-DM0 (YE)

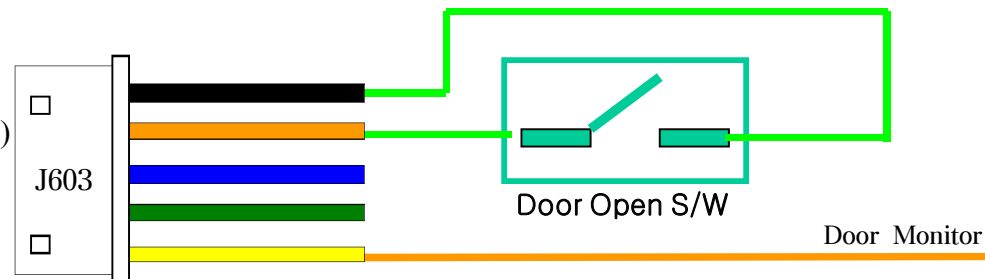

9. Connecting an EM Type Door Lock (Fail Safe)

9.1. Connecting One System/ One Lock

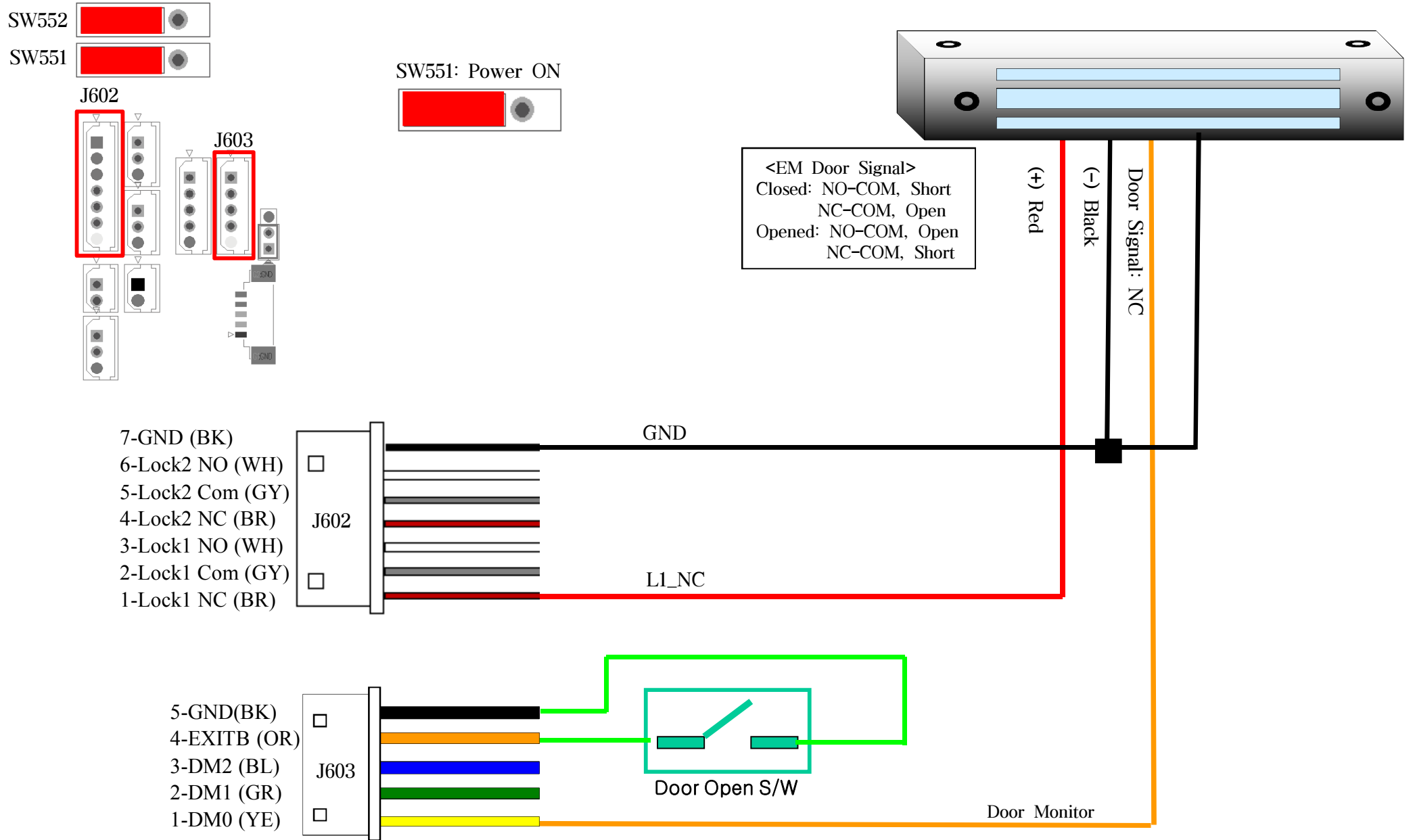

9. Connecting an EM Type Door Lock (Fail Safe)

9.2. Connecting Two Systems/ One Lock

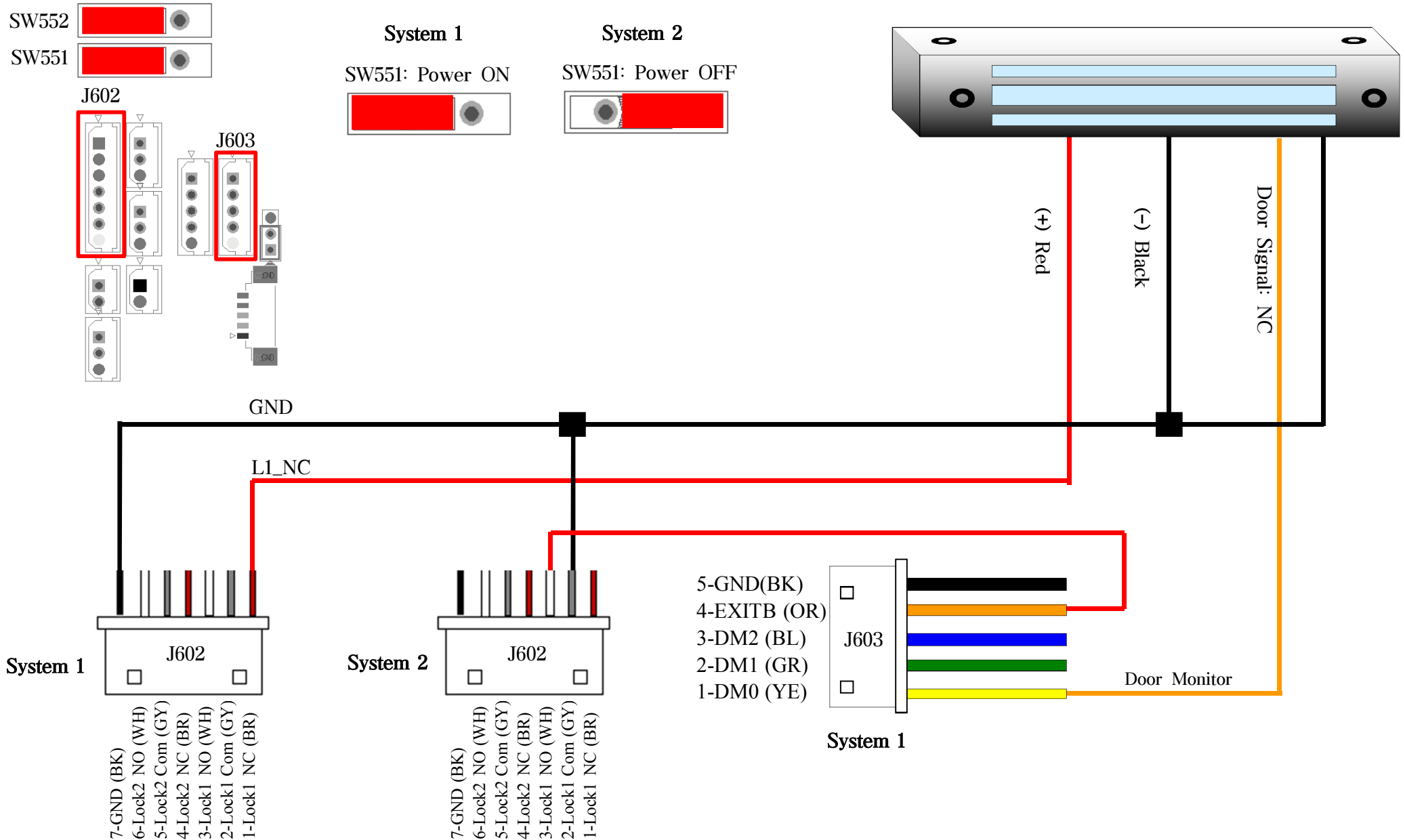

9. Connecting an EM Type Door Lock (Fail Safe)

9.3. Connecting One System/ Two Locks “ Use external DC Power adapter”

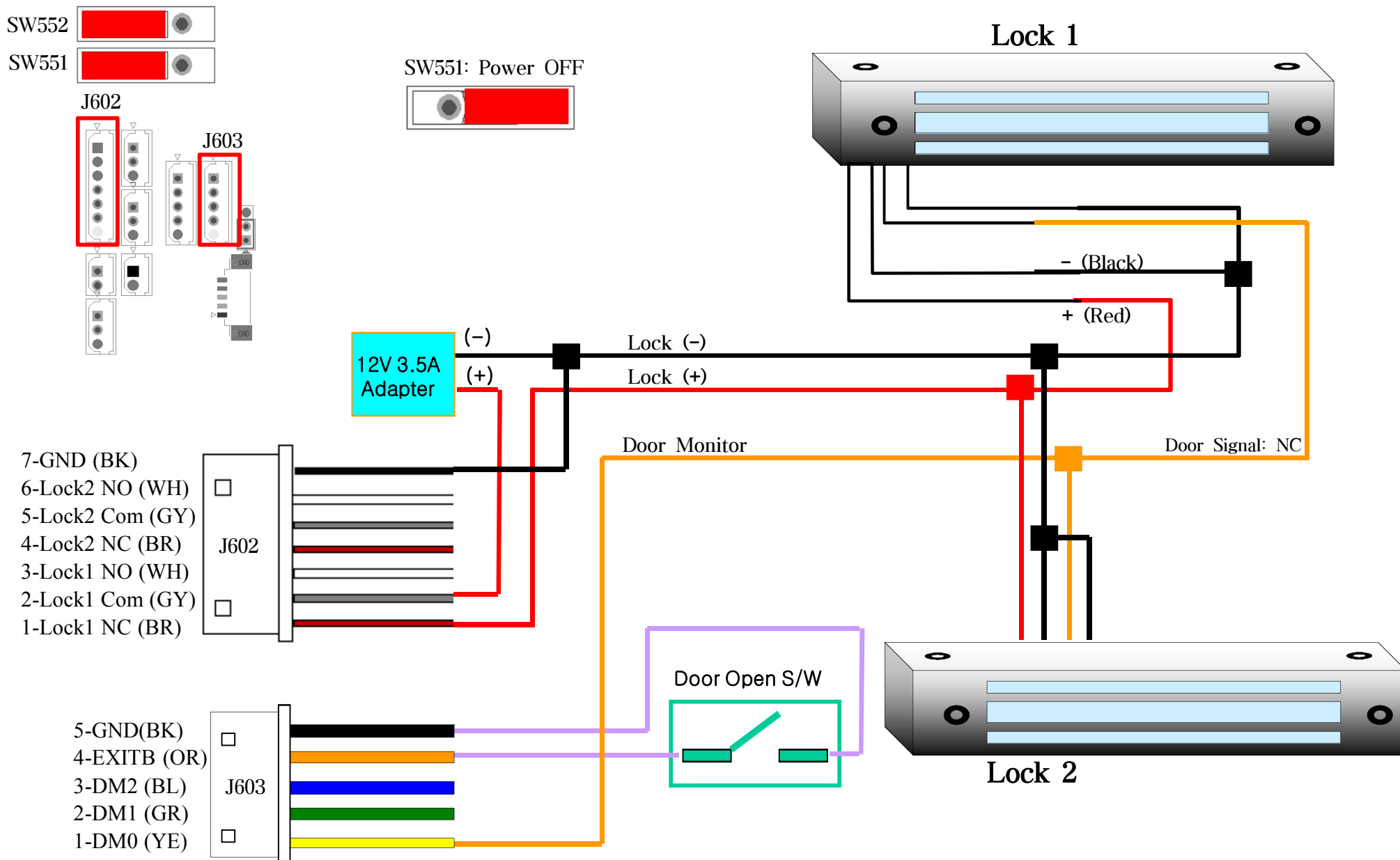

10. Connecting Auto-Door (Contact Control)

10.1. Connecting One System/ One Door

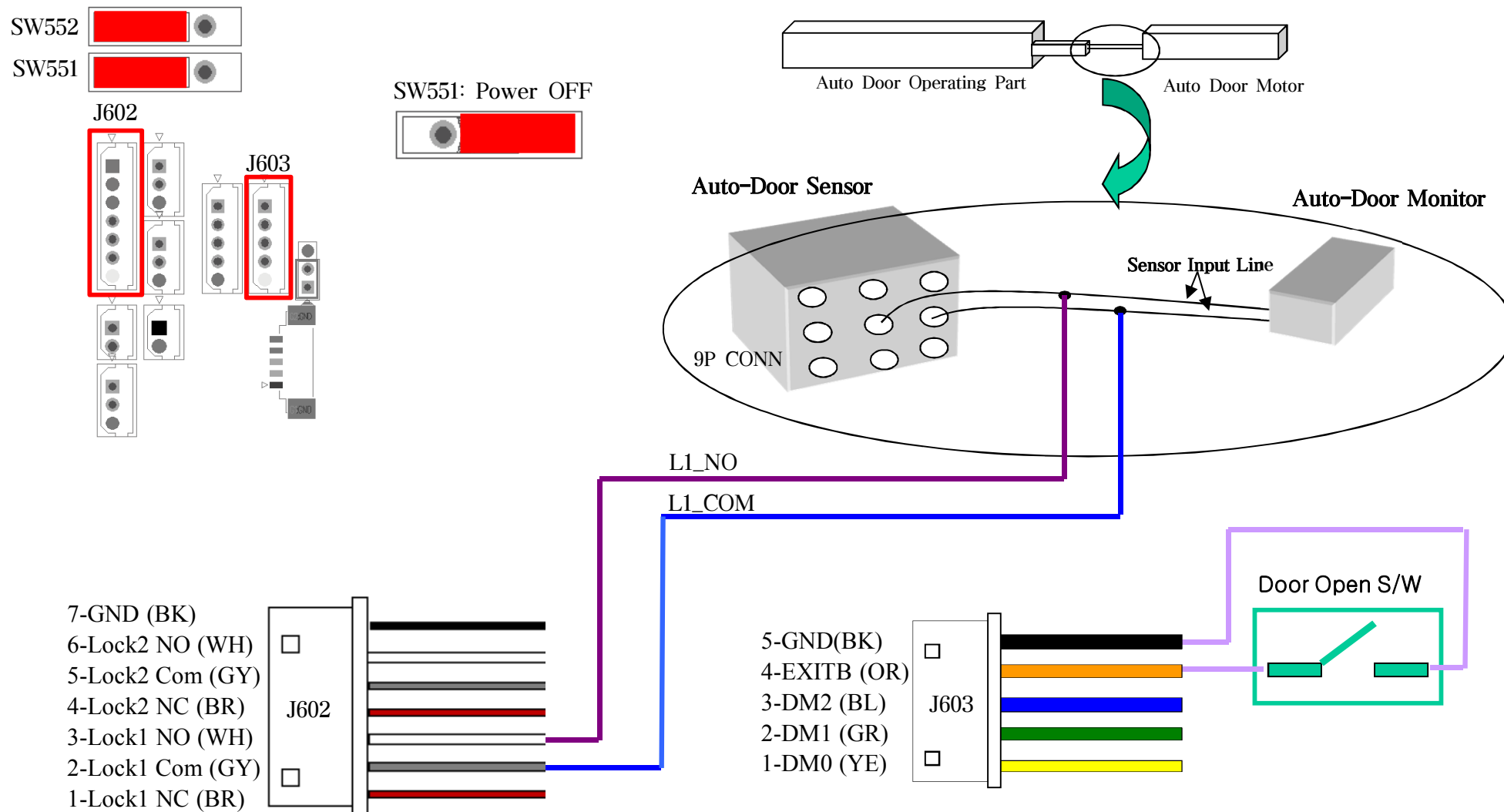

10. Connecting Auto-Door (Contact Control)

10.2. Connecting Two Systems/ One Door



System 1

System 2

SW551: Power OFF

SW551: Power OFF



J602

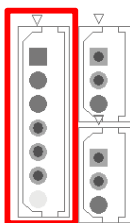

J603

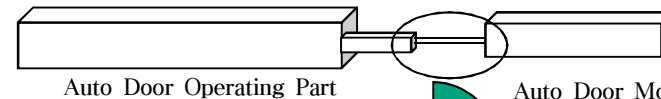
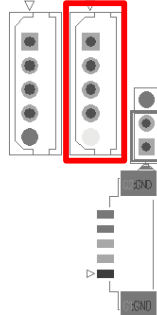

Auto Door Operating Part

Auto Door Motor

Auto-Door Sensor

Auto-Door Monitor

9P CONN

Sensor Input Line

LI_NO

LI_COM

System 1

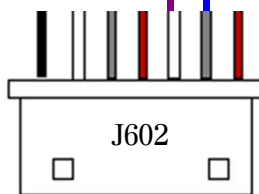

- 7-GND (BK)
- 6-Lock2 NO (WH)
- 5-Lock2 Com (GY)
- 4-Lock2 NC (BR)
- 3-Lock1 NO (WH)
- 2-Lock1 Com (GY)
- 1-Lock1 NC (BR)

System 2

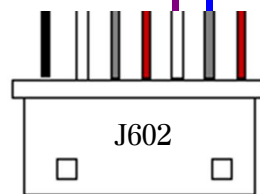

- 7-GND (BK)
- 6-Lock2 NO (WH)
- 5-Lock2 Com (GY)
- 4-Lock2 NC (BR)
- 3-Lock1 NO (WH)
- 2-Lock1 Com (GY)
- 1-Lock1 NC (BR)

11. Connecting a Motorised Lock

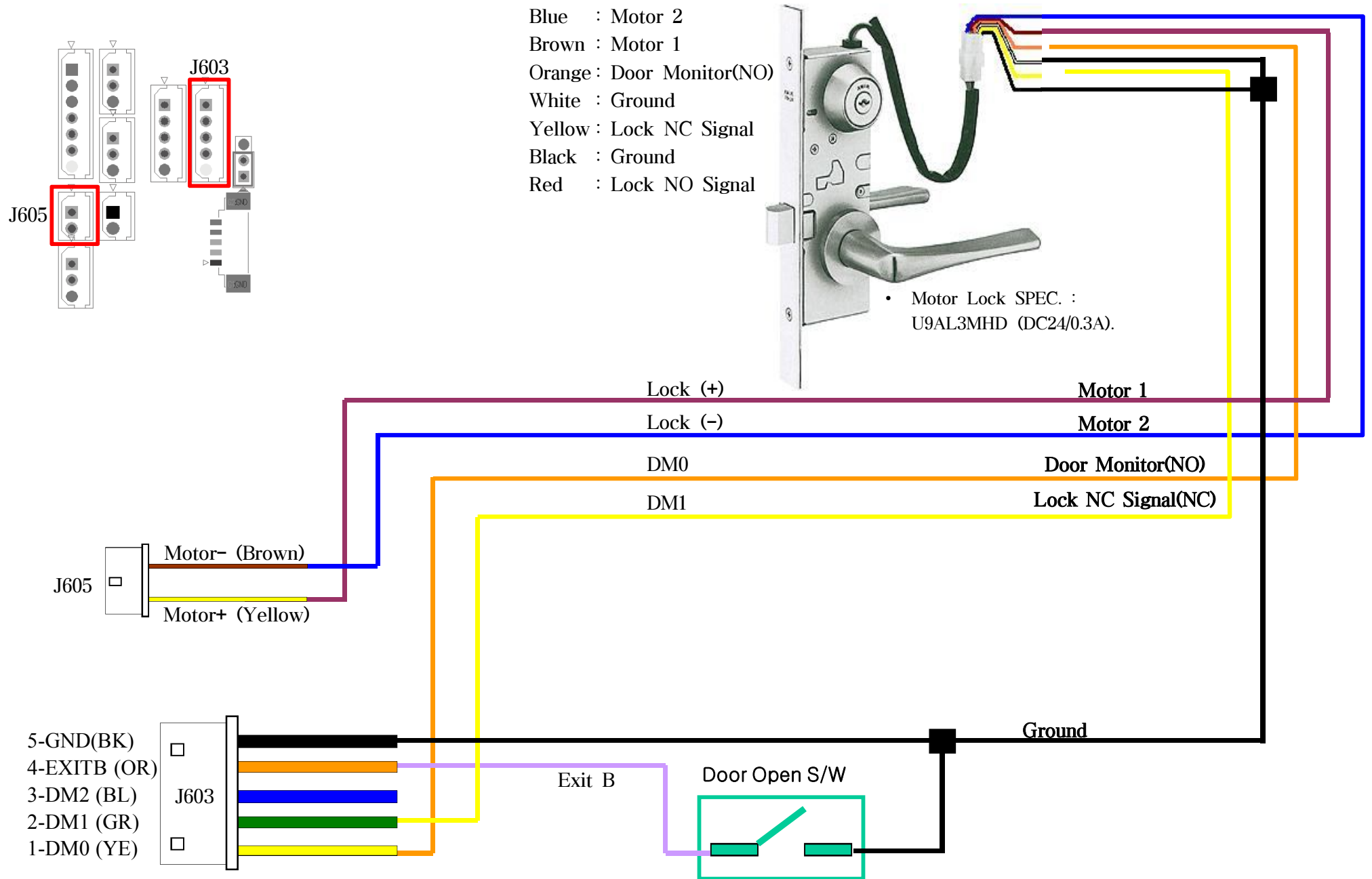

12. Connecting Two Emergency Lamps

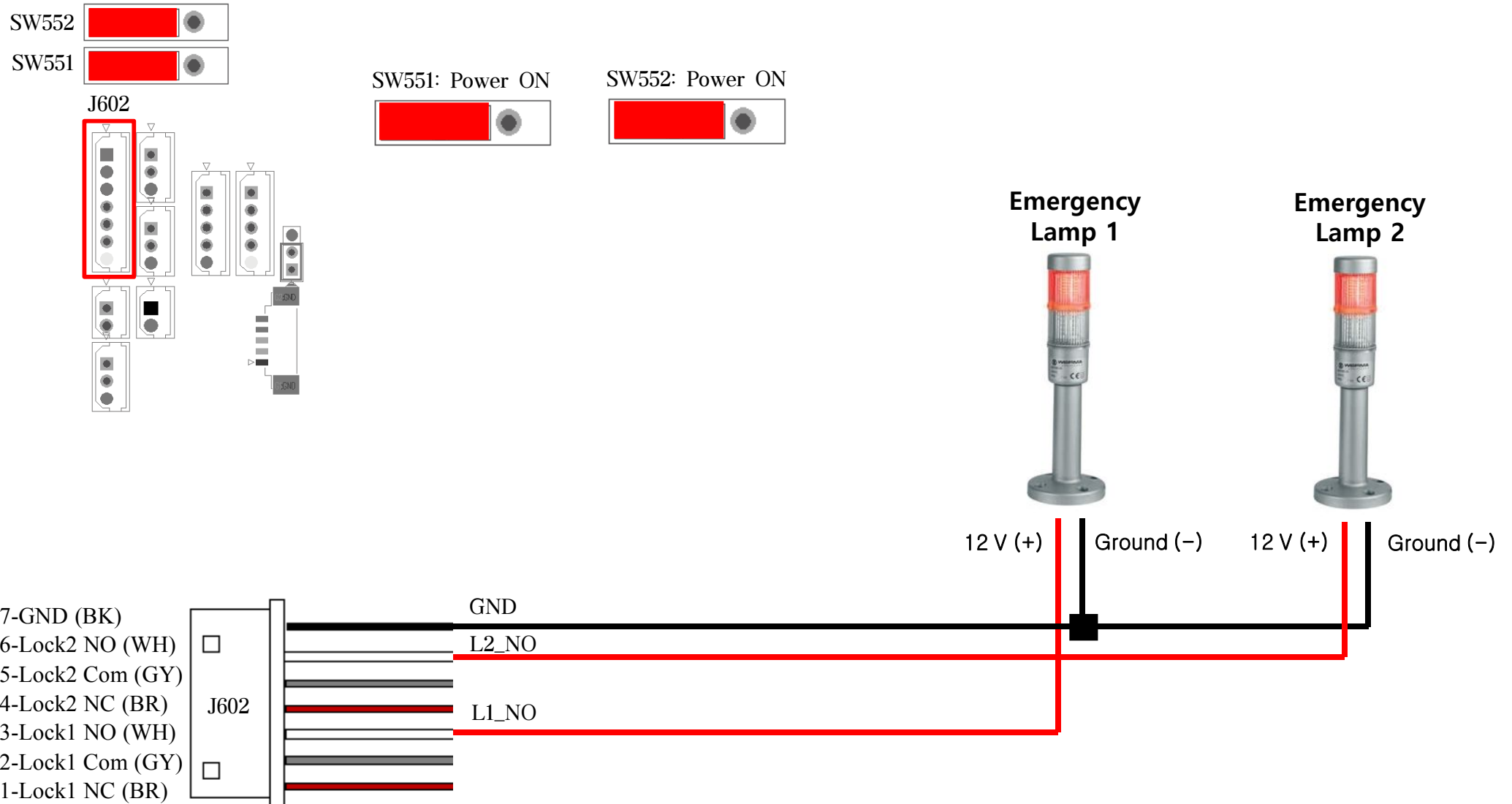

13. Appendix

13.1 How to connect an external relay

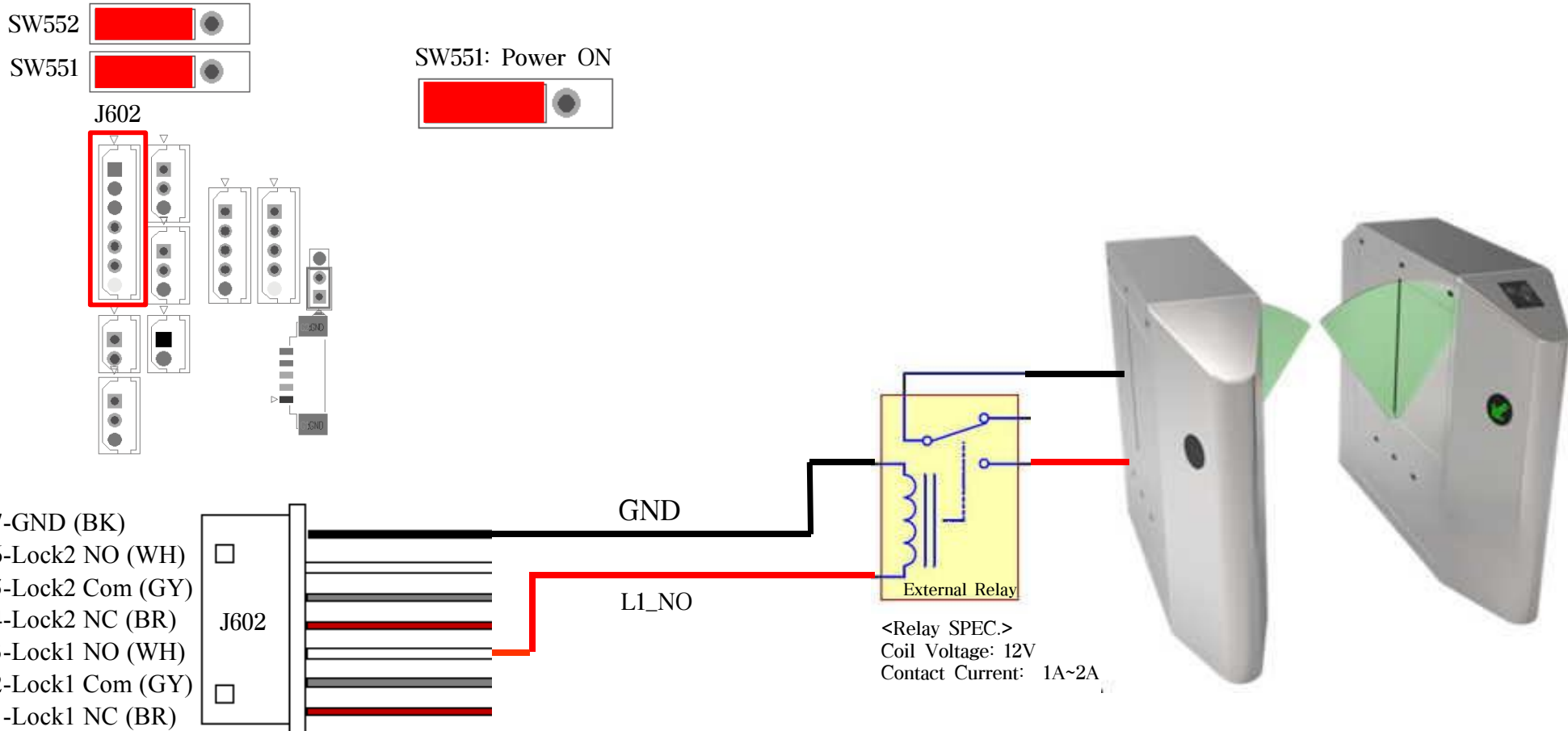

** It is recommended to connect an external relay if a problem occurs after connection with an external equipment such as a speed gate.

13. Appendix

13.2 How to connect the VS-R20D RF Dummy Card Reader

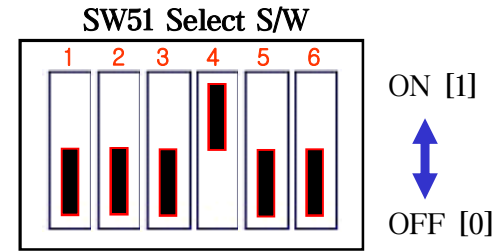
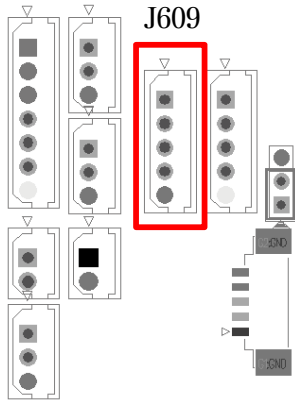

- * 1, 2, 3 OFF: 26Bit
- * 4 ON: Wiegand Mode



Wiegand Cable (5P)

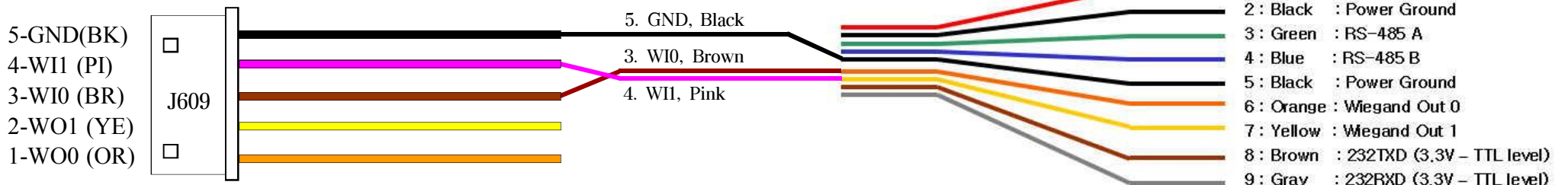

13. Appendix

13.3 How to connect the VS-R20D SC Dummy Card Reader

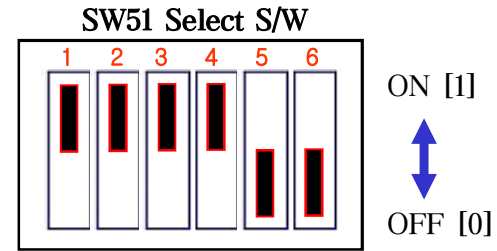
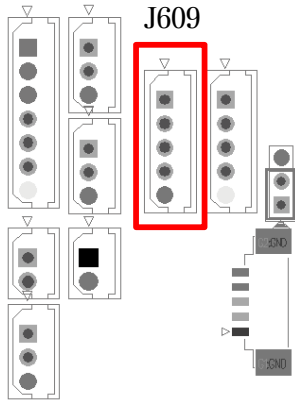

- * 1, 2, 3 ON: 34Bit
- * 4 ON: Wiegand Mode



Wiegand Cable (5P)

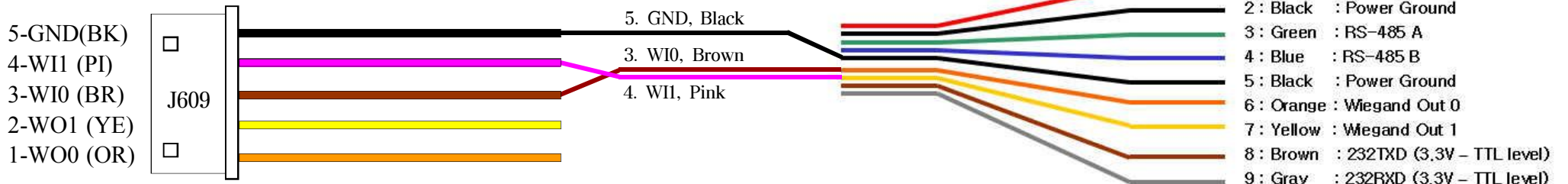

**** Recommend installation guide1 (RF & SC Card)**

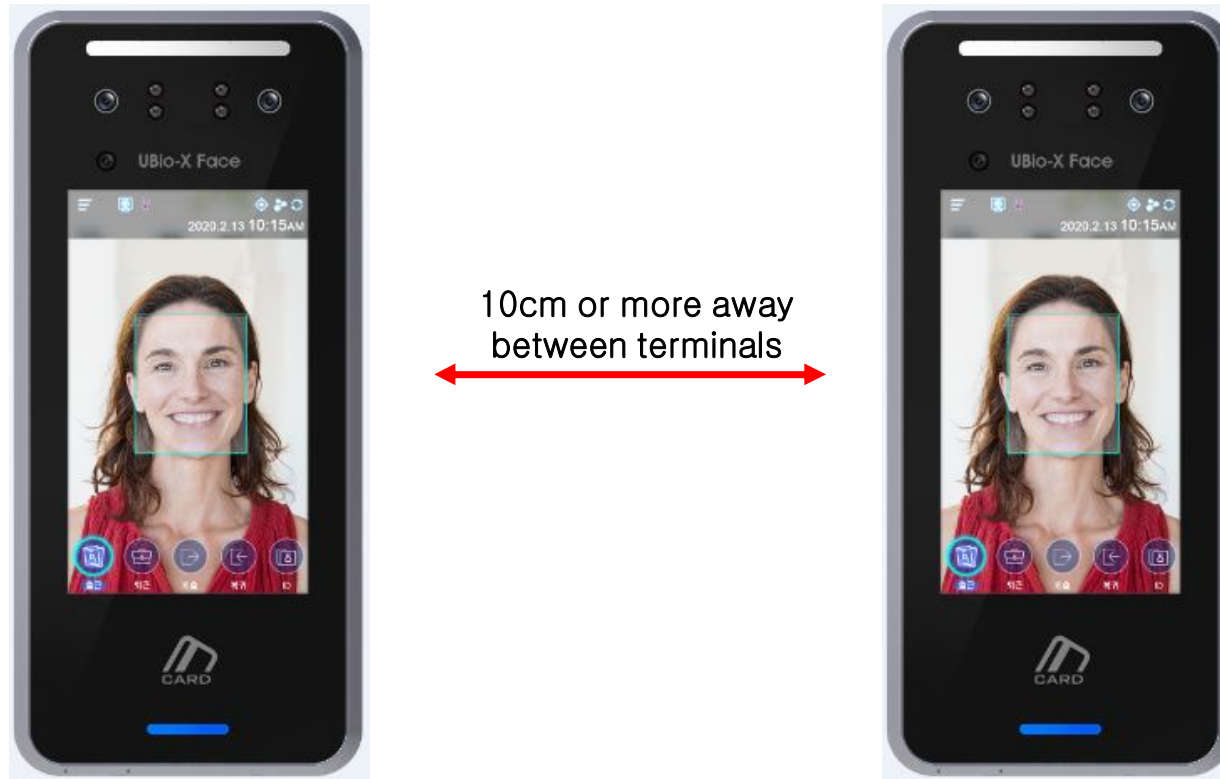

- ** In order to prevent RF / SC card antenna interference between products, install at least 10cm apart from each other.
- ** Card recognition distance may be reduced when installed within 10cm.

**** Recommend installation guide 2**

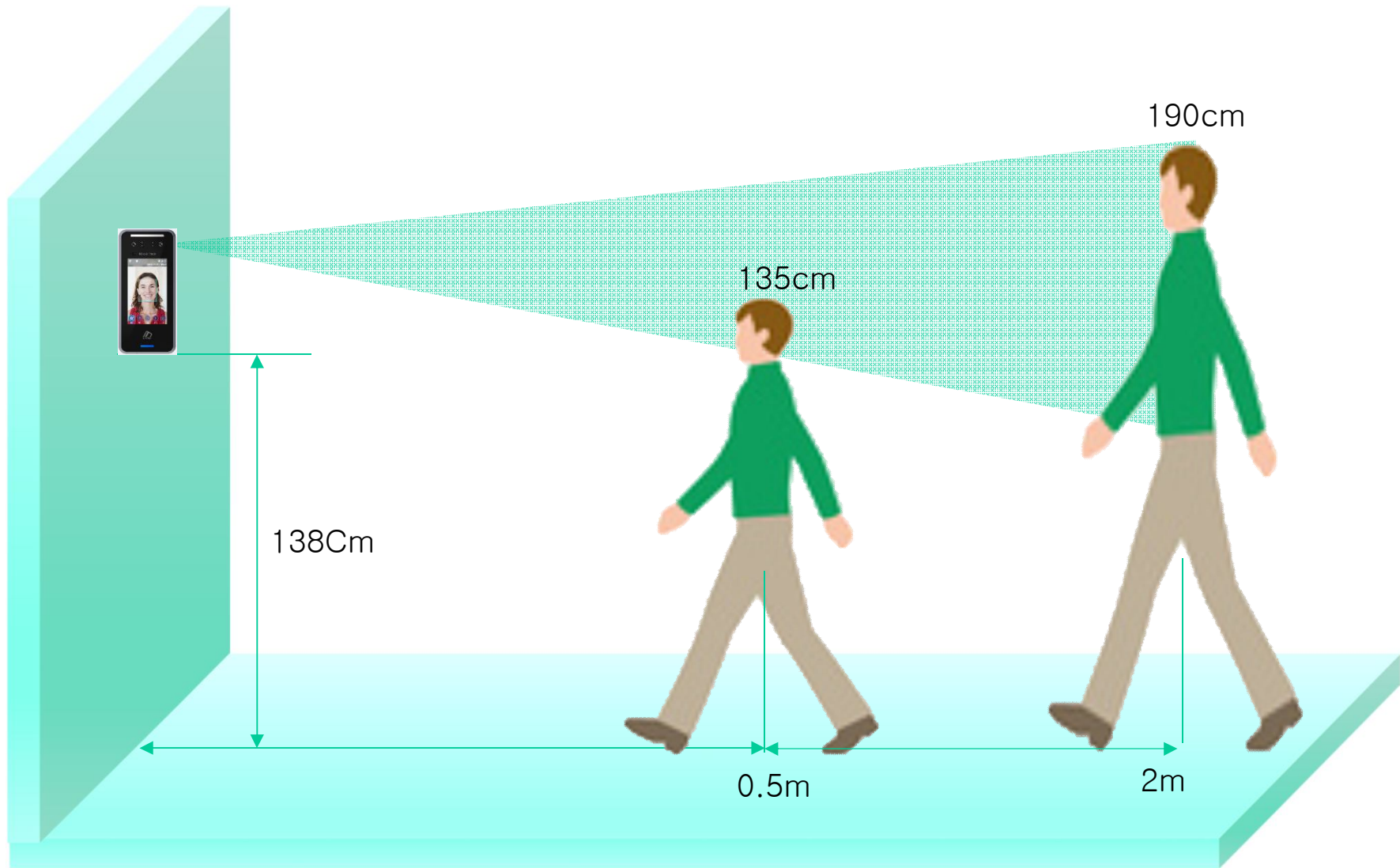

Distributed by



Trading Address: Unit A8 Caxton Point Business Centre, Caxton Point, Caxton Way, Stevenage, SG1 2XU, UK
Registered Office: c/o Becktech Limited, Terminus Road, Chichester, Sussex, PO19 8DW, UK
Telephone: +44 (0)1707 330 541 | Email: sales@genieproducts.co.uk