

HDMC221V2

ENCAPSULATED CAMERA

2.1MP HD-SDI Encapsulated Camera with 3.6mm Fixed Lens



Key Features

- 1/2.8" Progressive Scan CMOS
- 1080p (1920×1080) @ 30 (25)fps
- EX-SDI/HD-SDI/CVBS output
- Fixed lens 3.6mm
- Electronic Day & Night
- WDR, 3D DNR, Defog
- RS485 or AD KEY
- 30×30mm Mini square camera

The Genie HDMC221V2 is a 2.1MP HD-SDI encapsulated camera with a 3.6mm fixed lens.



Specification

Camera

Image Sensor	1/2.8" SONY Exmor R Progressive Scan CMOS
Resolution	HD-SDI/EX-SDI1.0_2.0_2.1: 1080p @ 30fps (25fps) / 720p @ 60fps (50fps) / 720p @ 30fps (25fps) TV out: CVBS NTSC / PAL (720H)
Electronic Shutter	AUTO / FLICKER / MANUAL / (1/30(25)~1/30,000)
Digital Slow Shutter (DSS)	OFF~ x32
Minimum Illumination	0.2 Lux (F2.0, AGC33dB, DSS:x2)
Lens	3.6mm, F 2.0, 112.3 (D) x 93.7 (H)x 49.3° (V) Angle of View
Effective Pixels	1945(H) x 1097(V)

Others

Power Supply	DC12V (±10%)
Power Consumption	Max.150mA @ DC12V
Temperature	-10°C~+50°C (Operating) -20°C~+60°C (Storage)
Dimensions	30 × 30 mm
Weight	Approx.28.9g (Board lens)

Functions

White Balance	AUTO/AUTO EXT/PUSH LOCK/MANUAL
Level	135.6dB
D-WDR	Off/On
WDR/BLC	OFF/BLC/HLC/WDR
Auto Gain Control (AGC)	OFF~45dB
Day&Night	AUTO/COLOUR/B&W (Electronic D&N)
Noise Deduction	3D-DNR (OFF/Low/Middle/High)
Motion Detection	OFF/ON (4 Zones)
Privacy Mask	16 Zones
Image Rotation	OFF/H-FLIP/V-FLIP/HV-FLIP
Defog	OFF/ON(AUTO/MANUAL)
Sharpness	Adjustable (0~10)
OSD Control	Cable JOYSTIC, RS-485 Control (Option)
Language	8 languages
Video Output	HD-SDI/EX-SDI1.0/EX-SDI2.0/EX-SDI2.1/CVBS

Dimensions

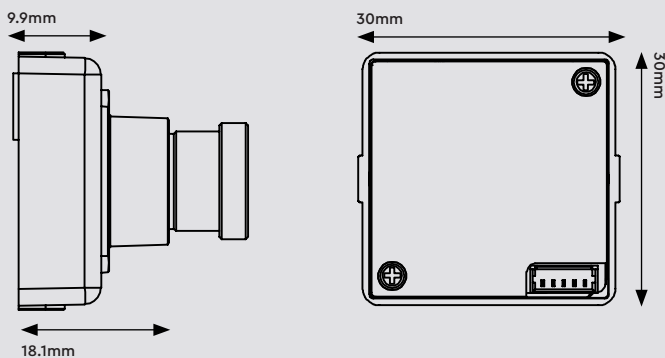

Accessories



PSU1SM

DC12V 1A Regulated Switch
Mode Power Supply