Installation & Wiring Guide

Fingerprint/Card Terminal

UBio-X Slim V1.0



Distributed by

genie

Doc. Ver. : V1.0

June.18, 2019

R&D Center

Union Community Co., Ltd.

1. Cable descriptions

1.1. Main Cable (18pin)

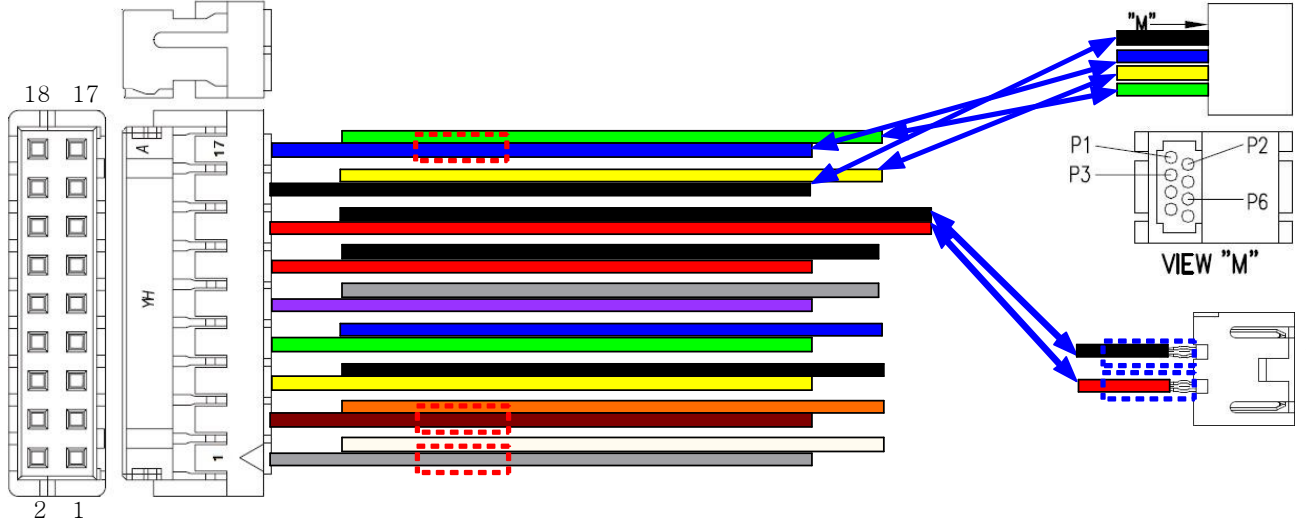

18pin Main Cable

1. Gray : Lock1 Com : L1C
 2. White : Lock1 NO : L1NO
 3. Brown : Lock1 NC : L1NC
 4. Orange : Exit : EXT
 5. Yellow : Monitor : DM0
 6. Black : Ground : GND
 7. Green : RS485A : R4A
 8. Blue : RS485B : R4B
 9. Violet : RS232TXD : R2T
 10. Gray : RS232 RXD : R2R
 11. Red : DC12V Out : 12V
 12. Black : Ground : GND
 13. Red : DC12V IN : 12V
 14. Black : Ground : GND
 15. Black : Ethernet TXP
 16. Yellow : Ethernet RXP
 17. Blue : Ethernet TXN
 18. Green : Ethernet RXN
- ** Pin1 & Pin 11 Shorted**

1.2. Sub Cable (12pin)

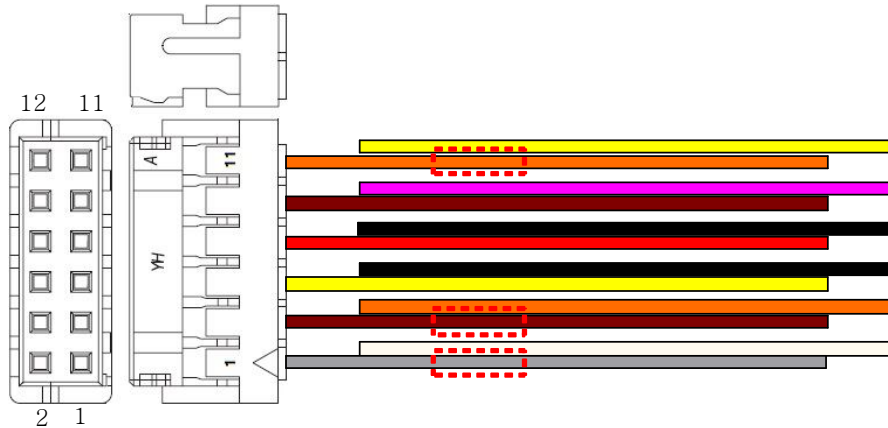

12pin Sub Cable

1. Gray : Lock2 Com : L2C
2. White : Lock2 NO : L2NO
3. Brown : Lock2 NC : L2NC
4. Orange : Aux IN1 : AIN1
5. Yellow : Aux IN2 : AIN2
6. Black : Ground : GND
7. Red : 5V Out : 5V
8. Black : Ground : GND
9. Brown : Wiegand IN 0 : Wi0
10. Pink : Wiegand IN 1 : Wi1
11. Orange : Wiegand Out 0 : WO0
12. Yellow : Wiegand Out 1 : WO1

2. Schematic for Door Lock Interface

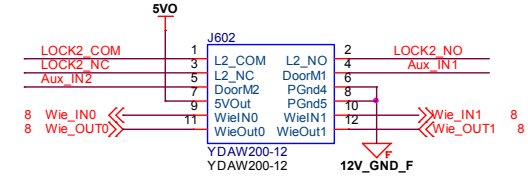
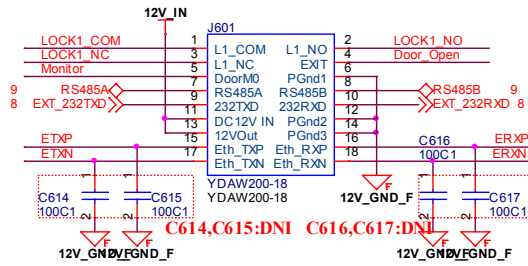
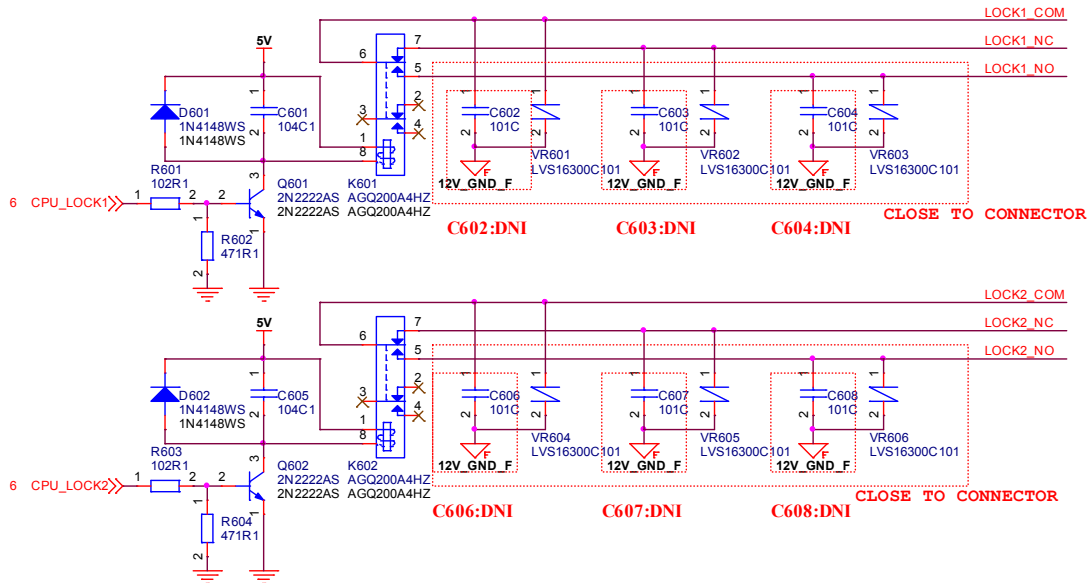

J601 (2mm Pitch, Dual, 18P Wafer) Pin Out

| | | | | | | | | |
|----|----|----|----|----|----|----|----|----|
| 01 | 03 | 05 | 07 | 09 | 11 | 13 | 15 | 17 |
| 02 | 04 | 06 | 08 | 10 | 12 | 14 | 16 | 18 |

J602 (2mm Pitch, Dual, 12P Wafer) Pin Out

| | | | | | |
|----|----|----|----|----|----|
| 01 | 03 | 05 | 07 | 09 | 11 |
| 02 | 04 | 06 | 08 | 10 | 12 |

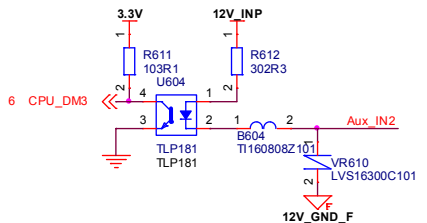
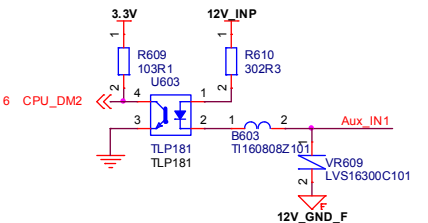
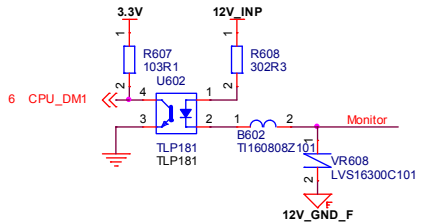
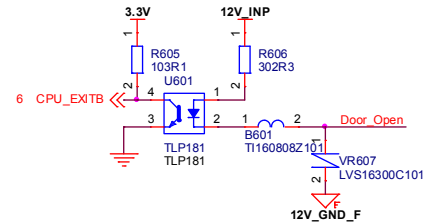

3. Connecting Dead-Bolt Type Door Lock (Fail Safe)

3.1. Connect with One System/ One Lock

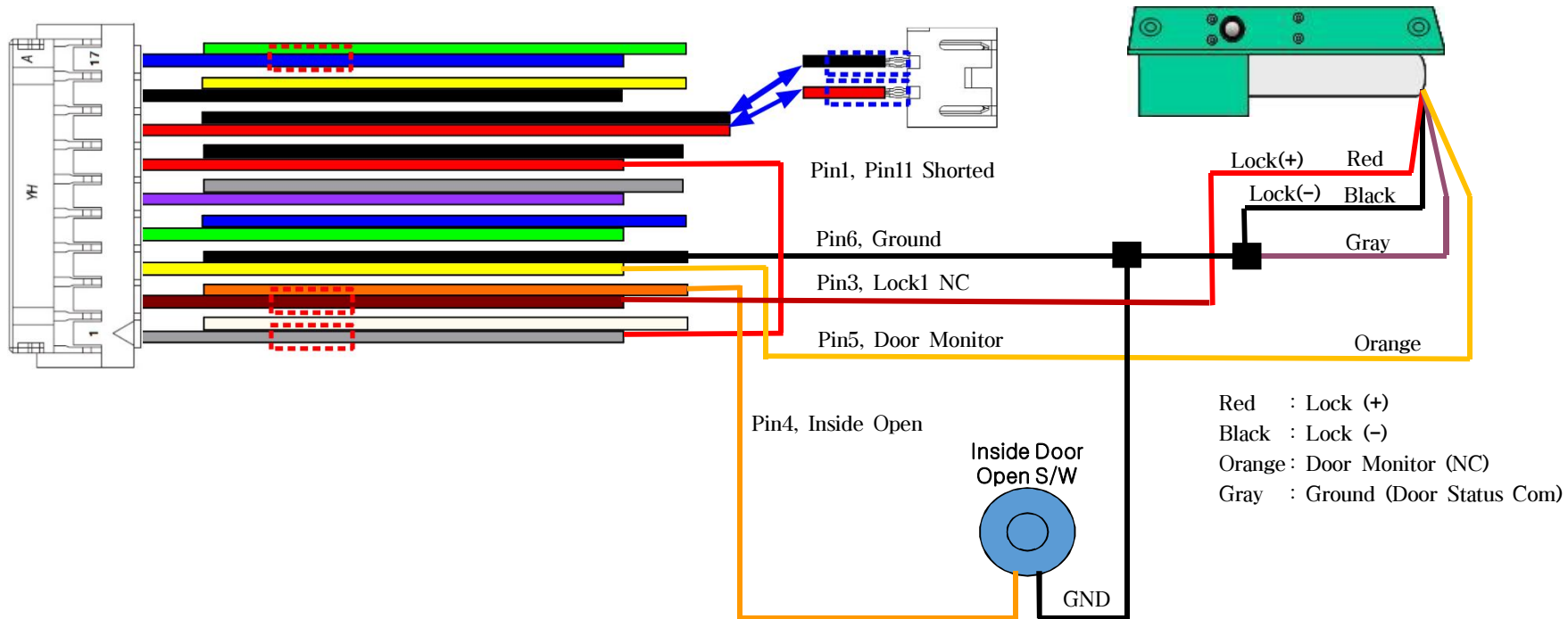

3. Connecting Dead-Bolt Type Door Lock (Fail Safe)

3.2. Connect with Two Systems/ One Lock

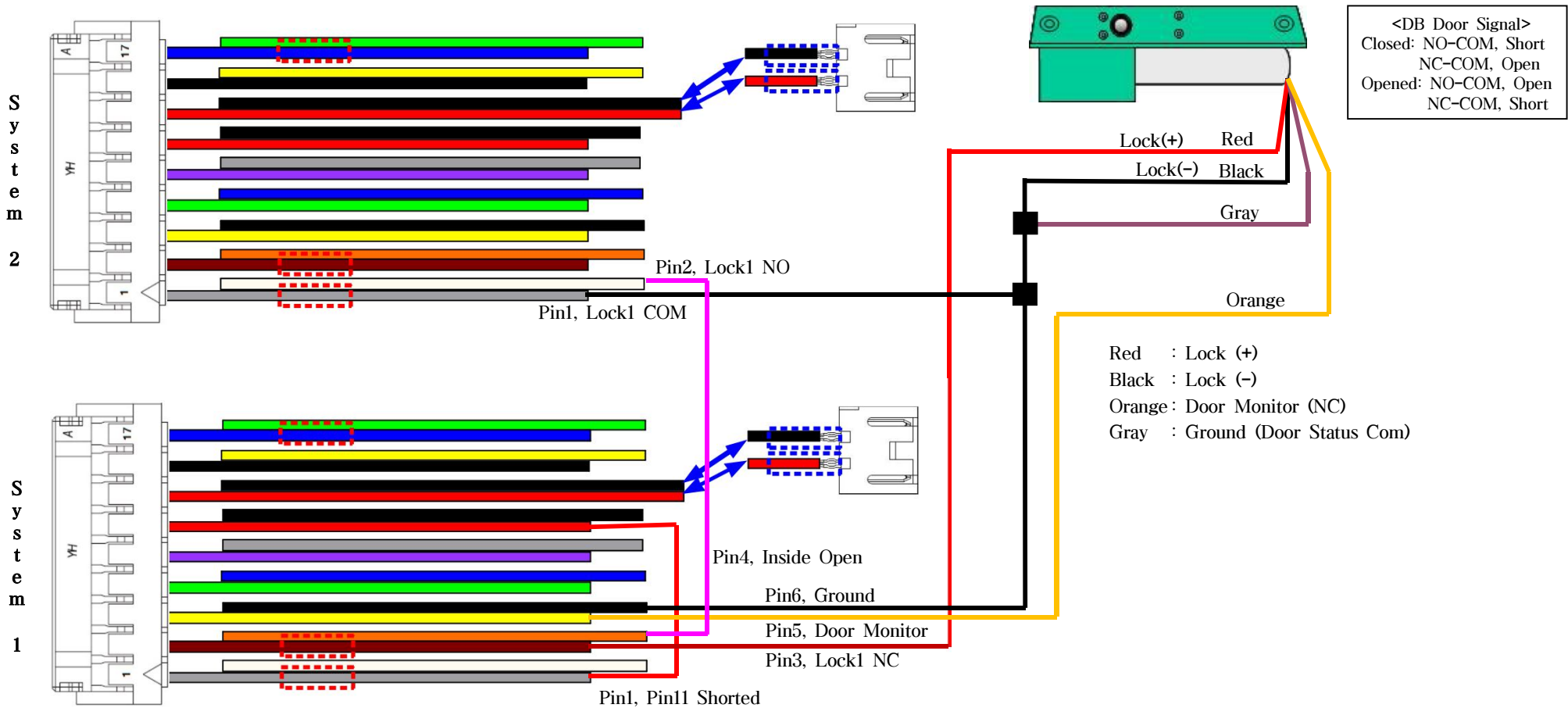

4. Connecting Strike Type Door Lock (Fail Safe)

4.1. Connect with One system/ One Lock

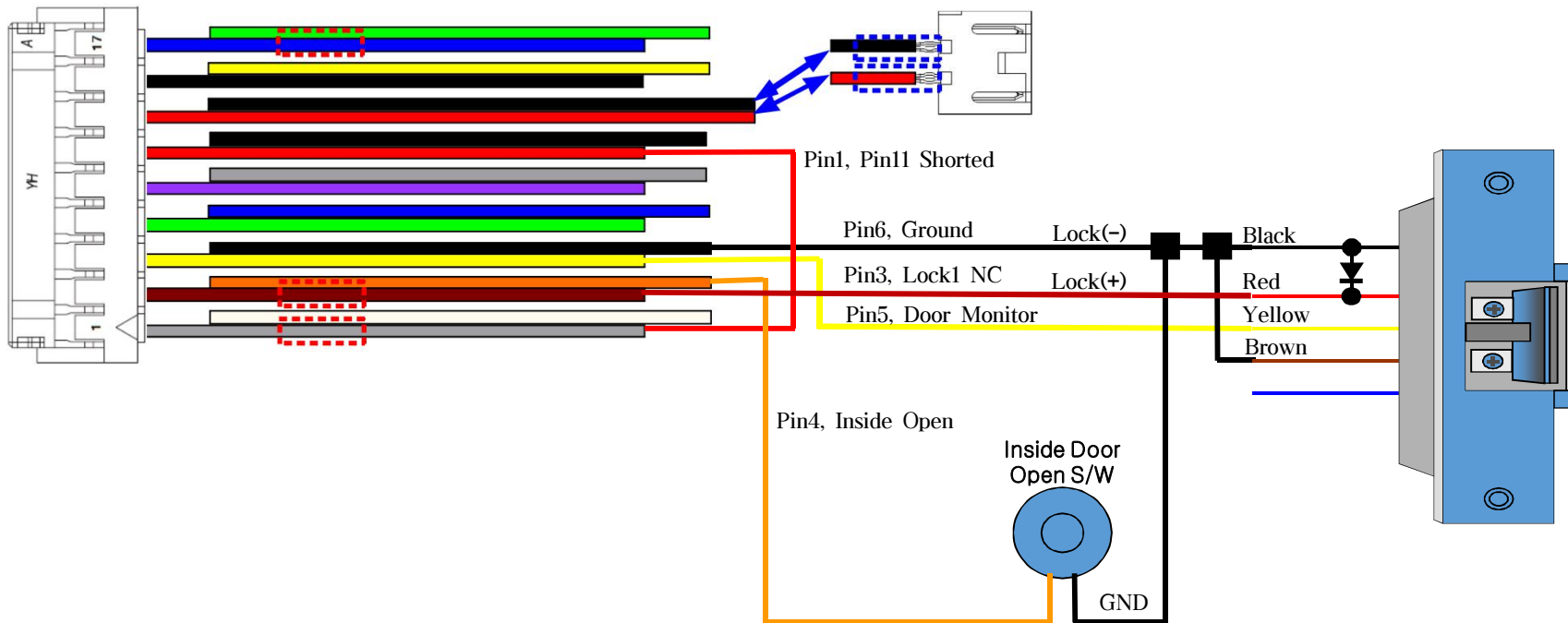

4. Connecting Strike Type Door Lock (Fail Safe)

4.2. Connect with Two systems/ One Lock

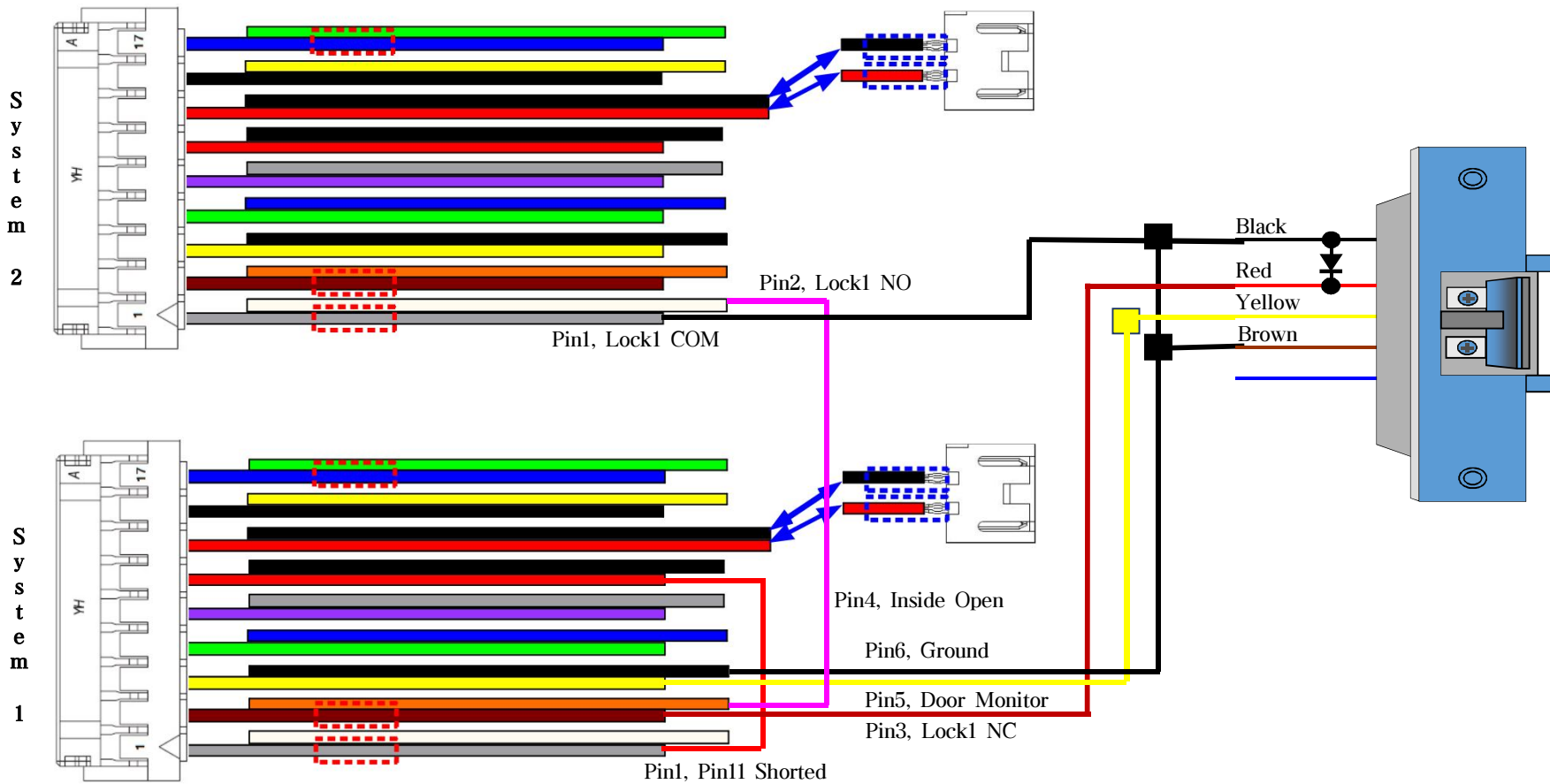

5. Connecting Strike Type Door Lock (Fail Secure)

5.1. Connect with One system/ One Lock

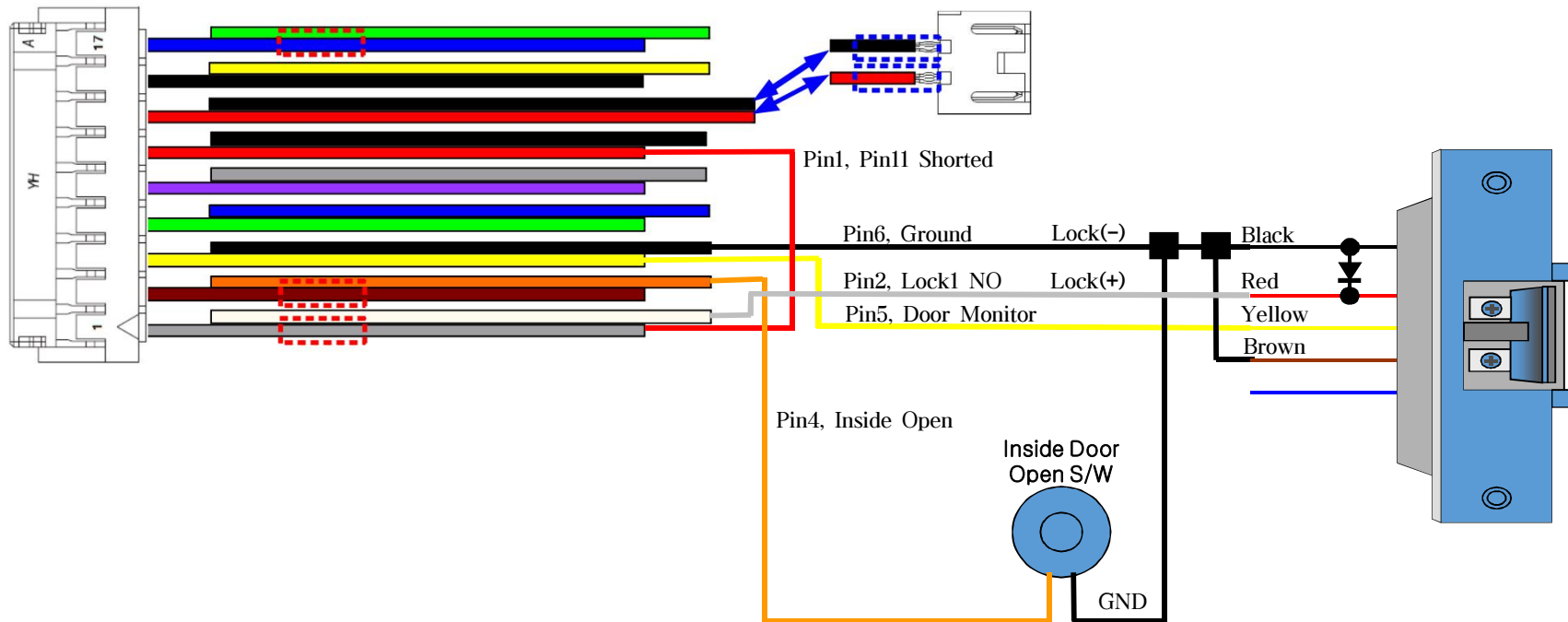

5. Connecting Strike Type Door Lock (Fail Secure)

5.2. Connect with Two systems/ One Lock

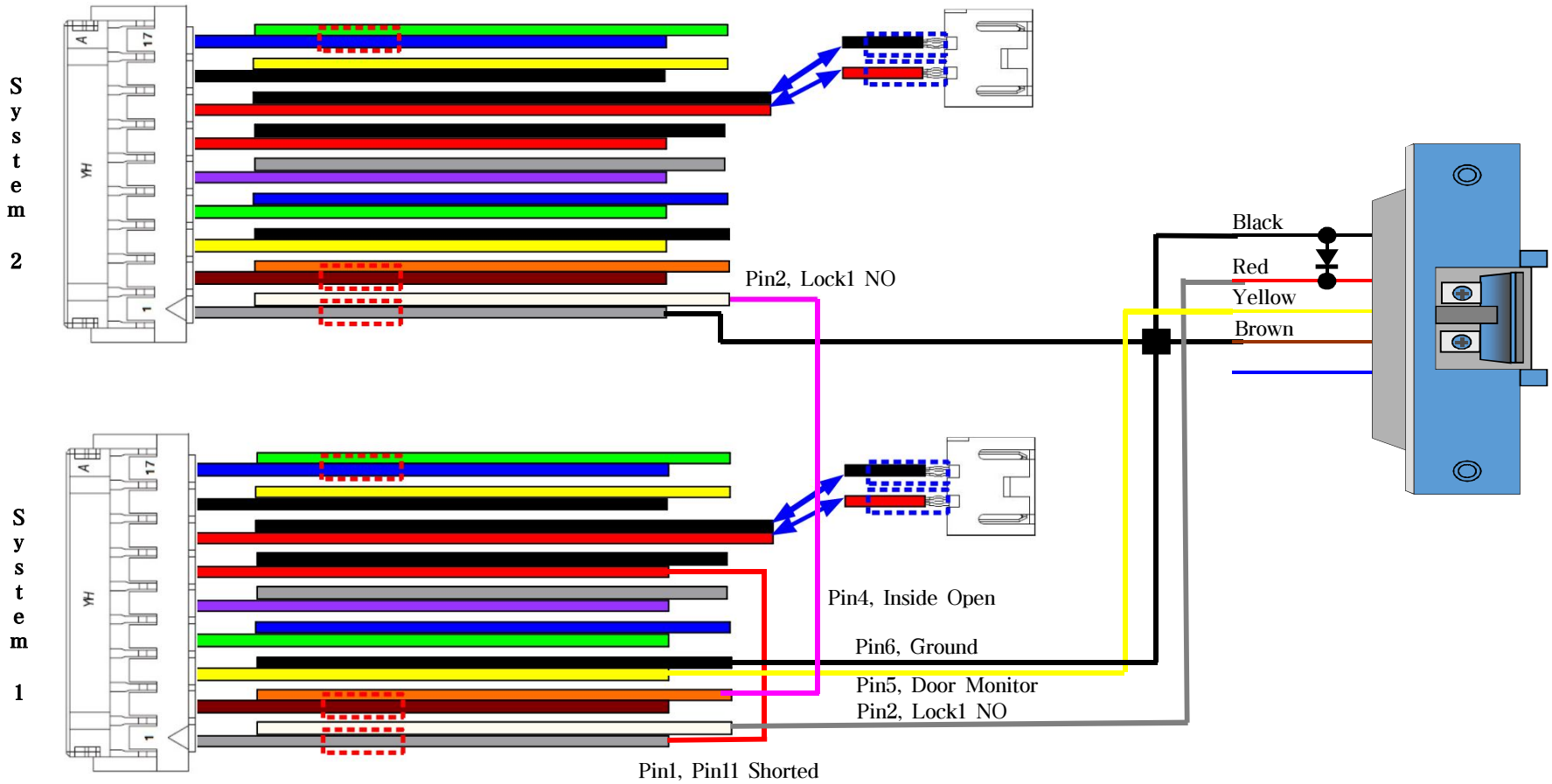

6. Connecting EM Type Door Lock (Fail Safe)

6.1. Connect with One system/ One Lock

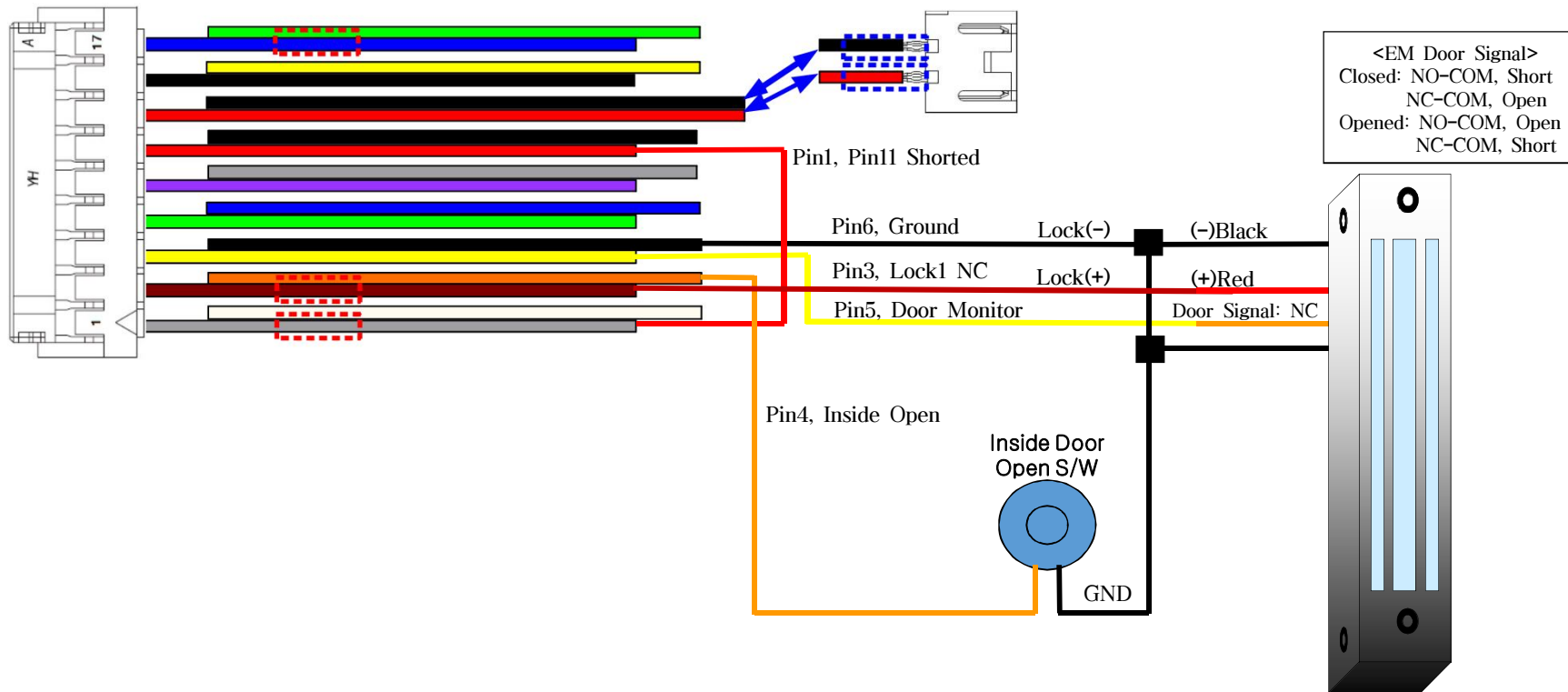

6. Connecting EM Type Door Lock (Fail Safe)

6.2. Connect with Two System/ One Lock

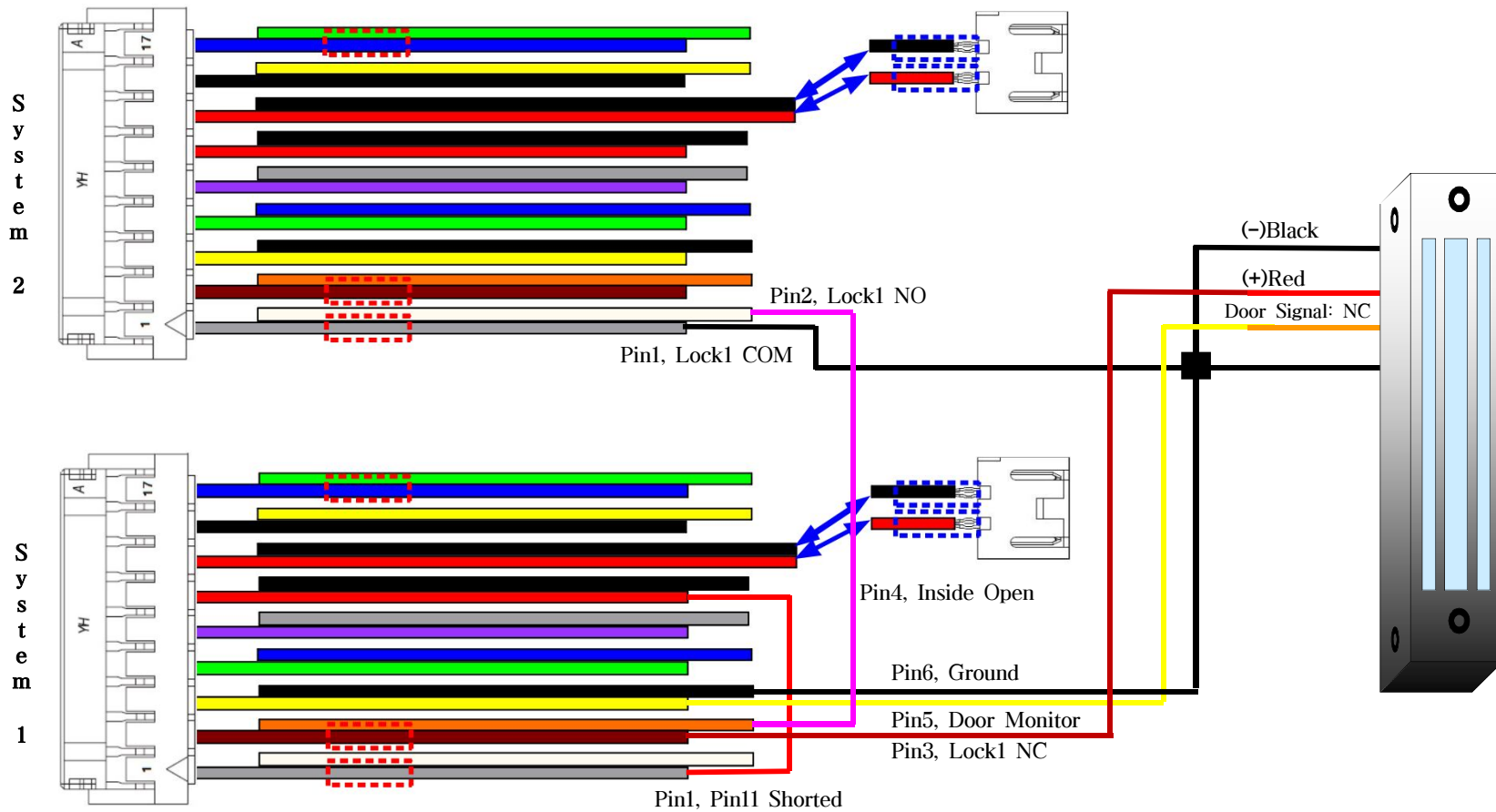

6. Connecting EM Type Door Lock (Fail Safe)

6.3. Connect with One system/ Two Locks ** Use external DC Power adapter

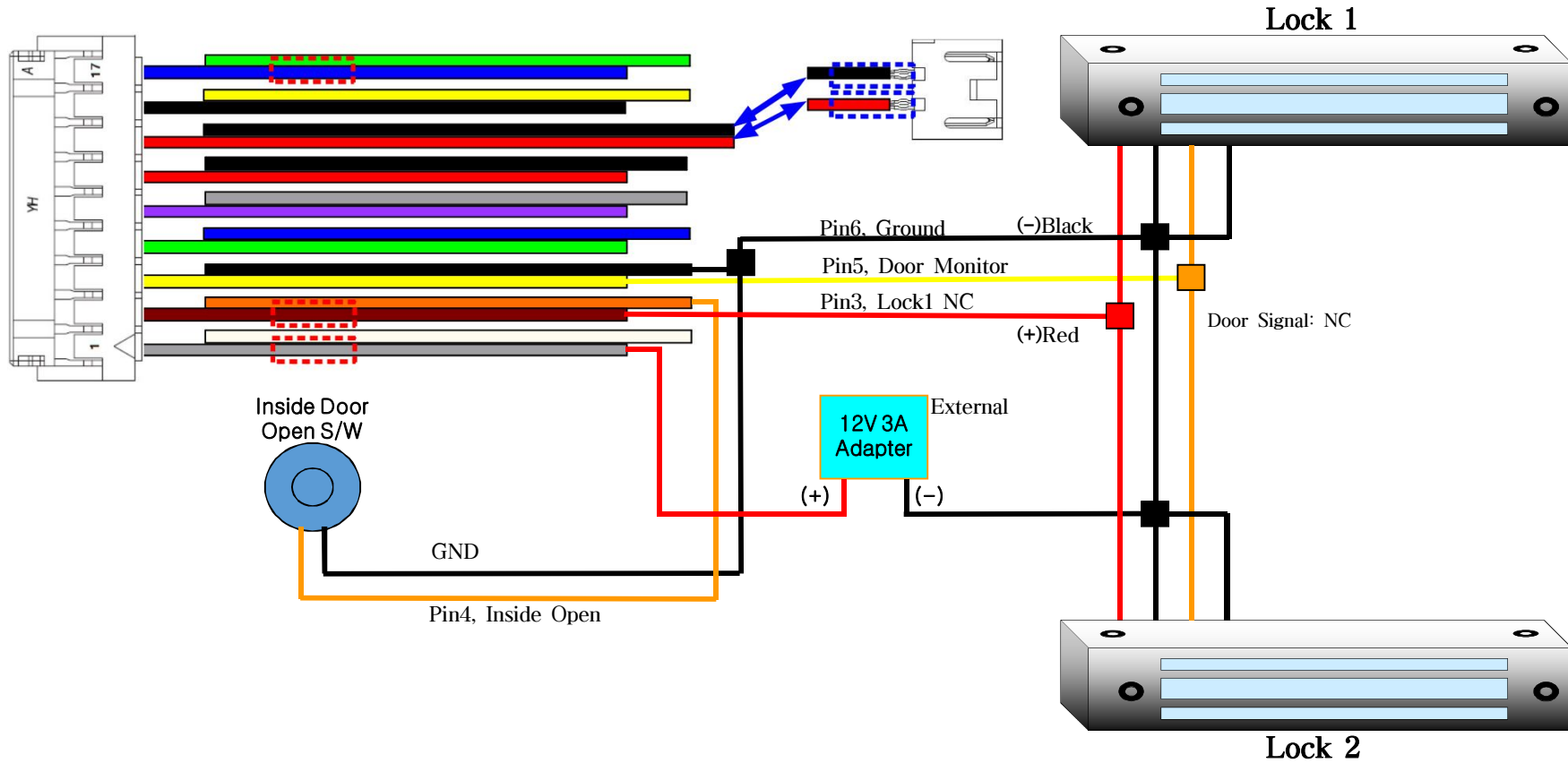

7. Connecting Auto-Door (Contact Control)

7.1. Connect with One system/ One Door

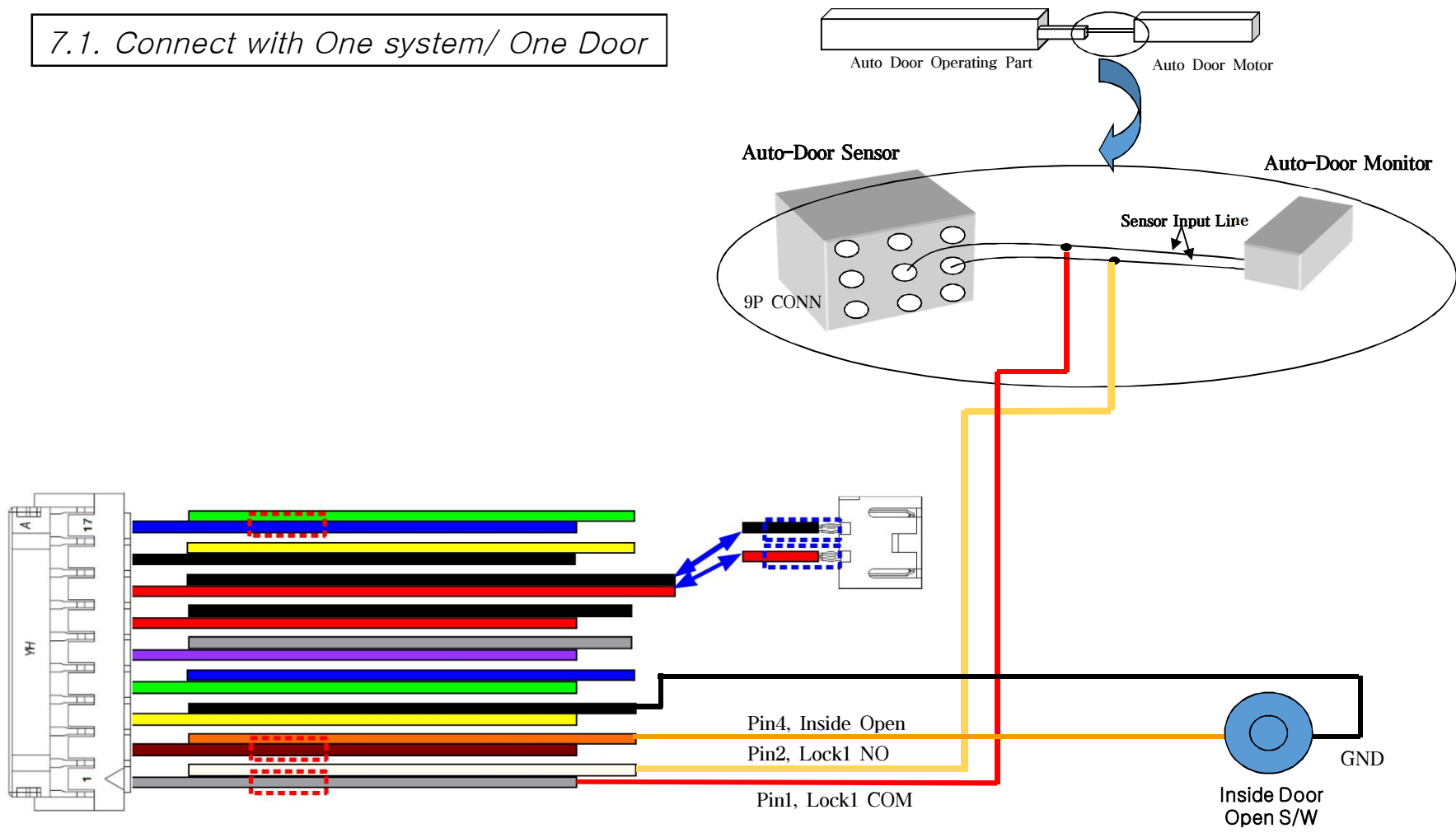

7. Connecting Auto-Door (Contact Control)

7.2. Connect with Two systems/ One Door

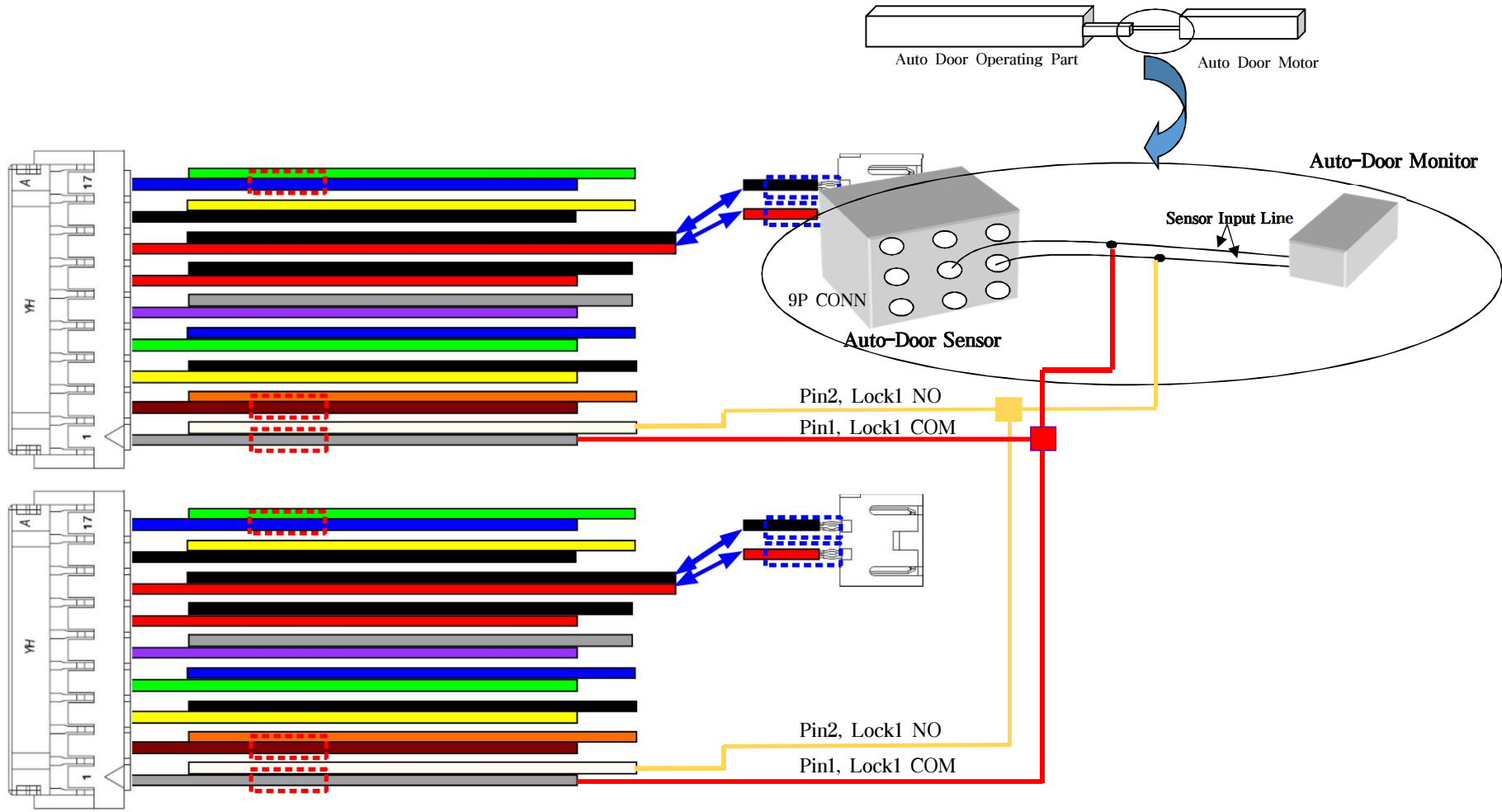

8. Connecting Motorised Lock

8.1. Connect with Motor Lock

- Blue : Motor 2
- Brown : Motor 1
- Orange : Door Monitor(NO)
- White : Ground
- Yellow : Lock NC Signal
- Black : Ground
- Red : Lock NO Signal

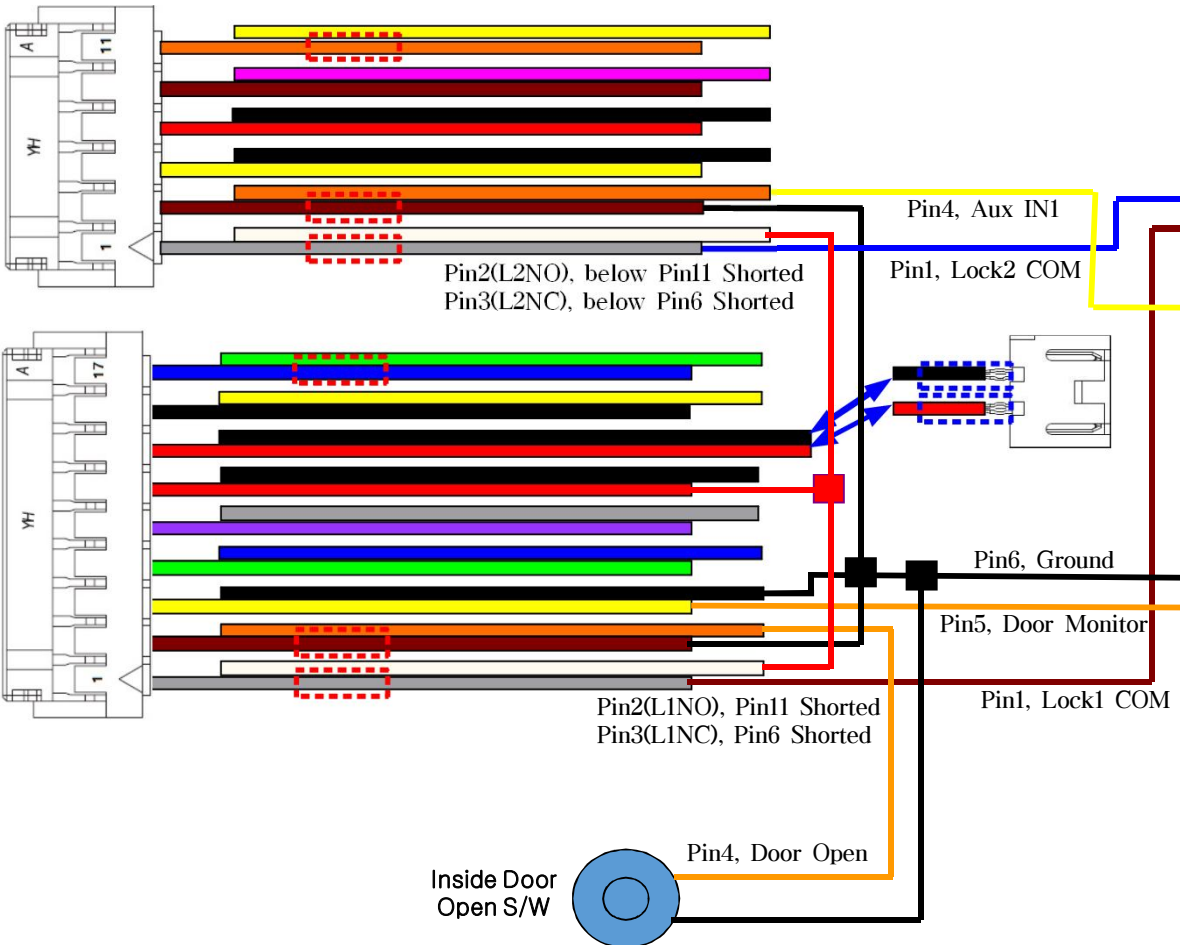

** Motor Lock SPEC. : U9AL3MHD (DC24/0.3A).
 ** Select motor lock 1st in the Lock setting at the menu.

10. Connecting Wiegand Output to External Controller

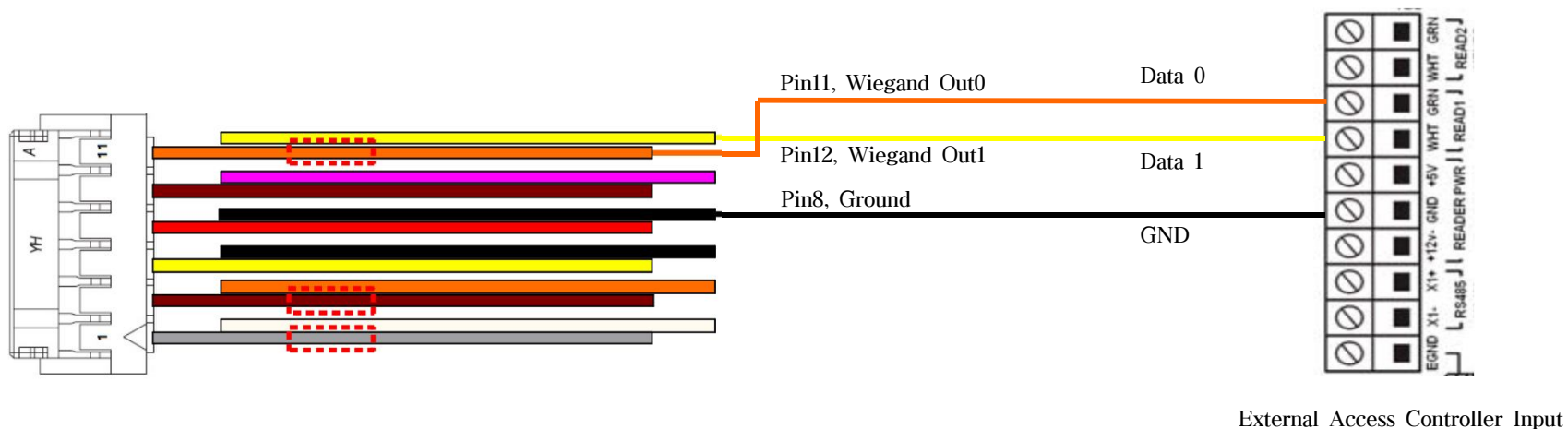

Supported Formats

-26 bits

-34 bits

(Site Code + User ID) = User Card number for controller

11. Appendix

11.1 RS-232 Interface

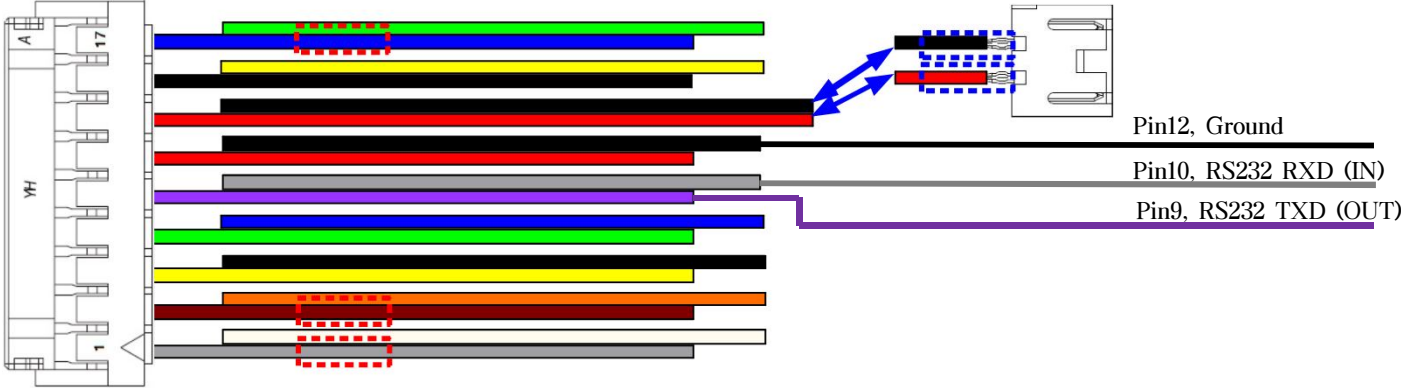

11. Appendix

11.2 RS-485 Interface

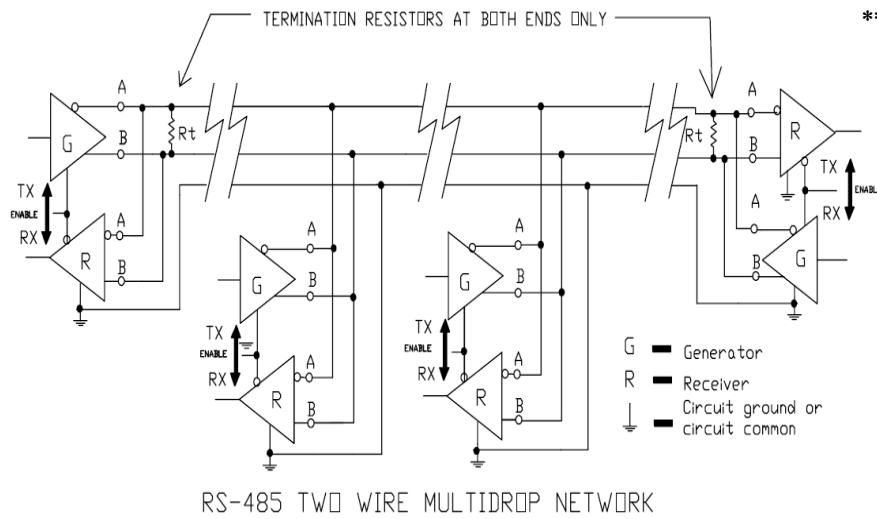
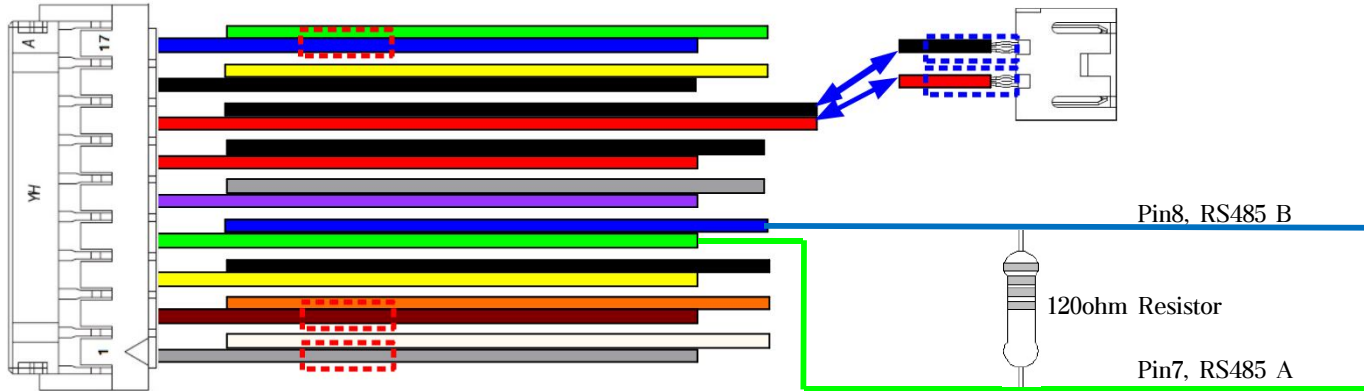

** When you need a termination resistor, connect 120ohm Resistor between RS485A and RS485B.

11. Appendix

11.3 WIFI Dongle Insert after assembly

** Open the Bottom cover.

Unlock the camera connector & pull out the cable in position A.

Unlock the touch screen connector & pull out the cable in position B.

Loosen the six angle screw boss in position C.

Loosen the screws in position D, E, F.

Insert the WIFI Dongle in position G after pull up the left side of Main PBA.

And then re-assemble in reverse order.

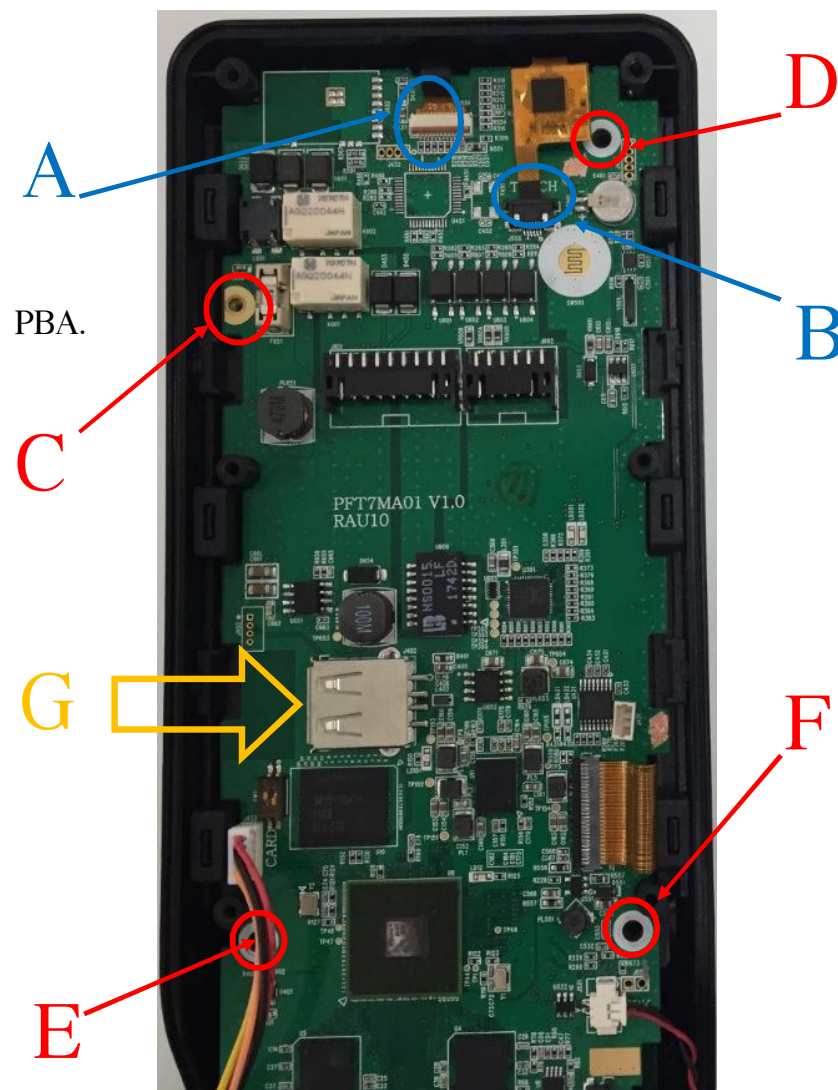

11. Appendix

11.4 How to connect an external relay

** It is recommended to connect an external relay if a problem occurs after connection with an external equipment such as a speed gate.

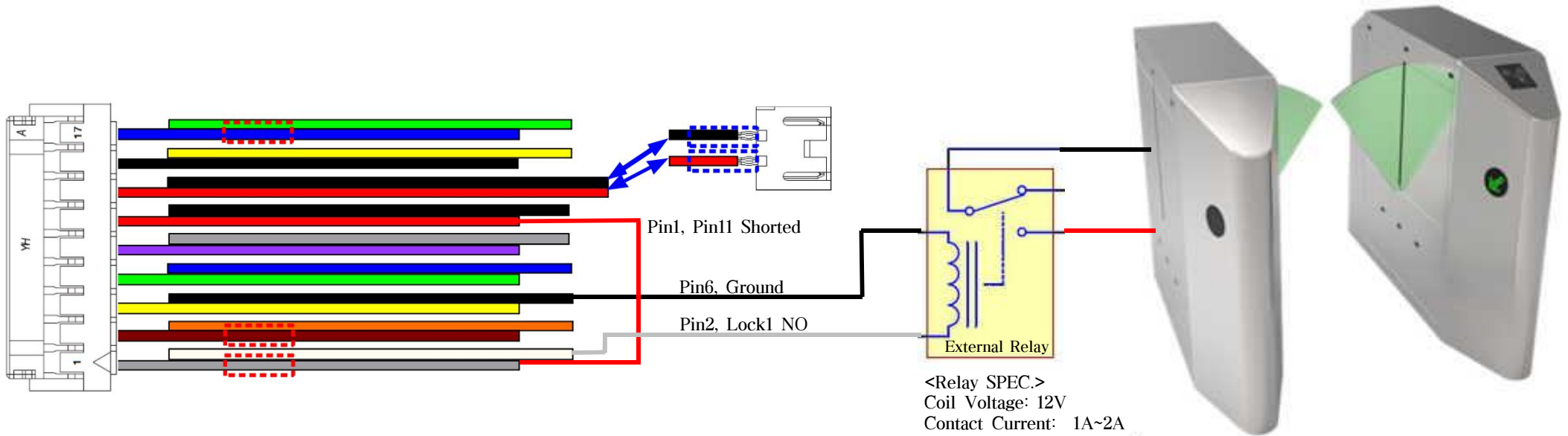

11. Appendix

11.5 How to connect the VS-R20D RF Dummy Card Reader



* 1, 2, 3 OFF: 26Bit
 * 4 ON: Wiegand Mode

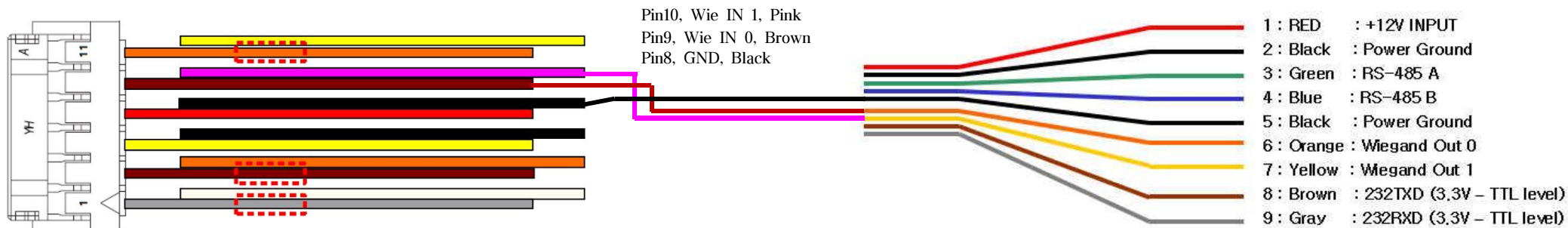

11. Appendix

11.5 How to connect the VS-R20D SC Dummy Card Reader

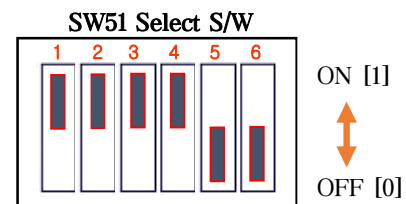

- * 1, 2, 3 ON: 34Bit
- * 4 ON: Wiegand Mode

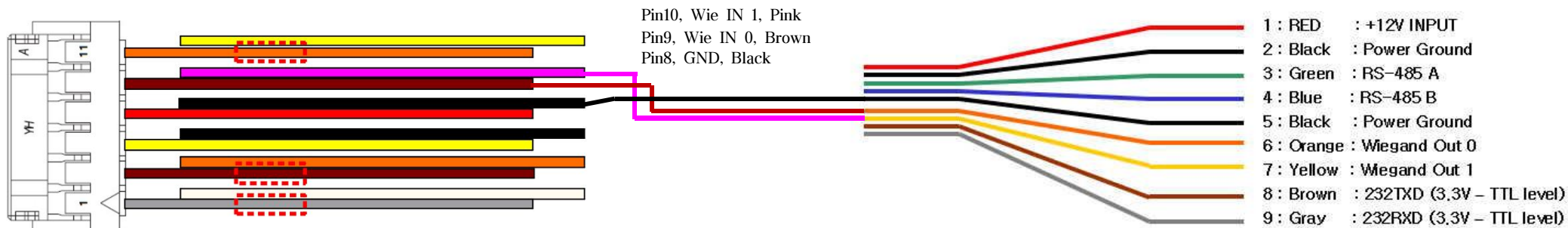

11. Appendix

11.6 The maximum cable length & thickness for installation

1) Using 12V 3.5A Power Supply & AWG24

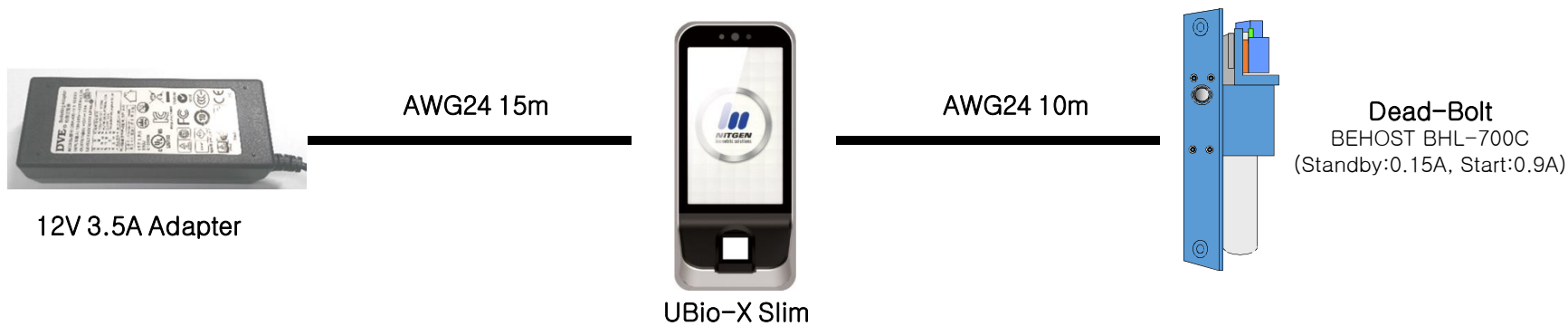

2) Using 12V 3.5A Power Supply & AWG22

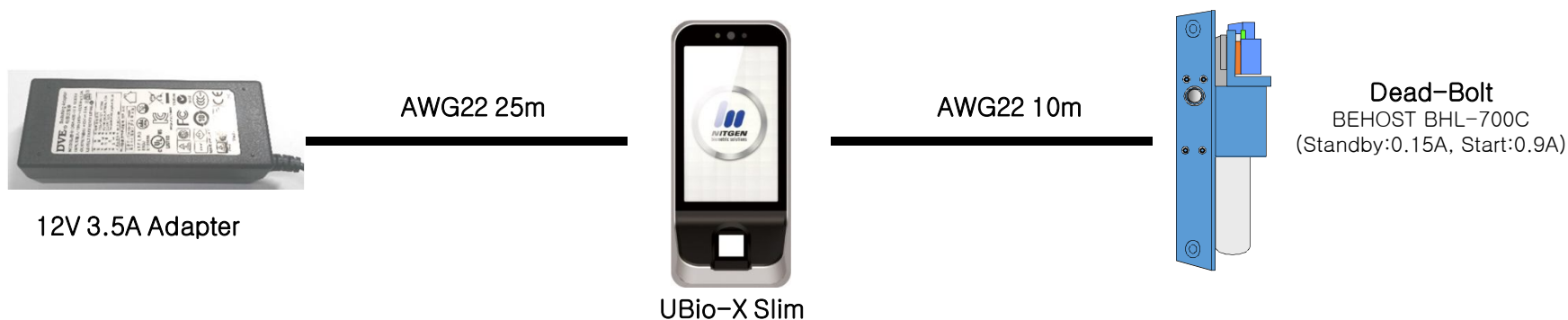

* Caution: The above data are the measured values when using the adapters and the dead-bolts provided by the Union Community.

11. Appendix

3) Using 12V 3.5A Power Supply & AWG20

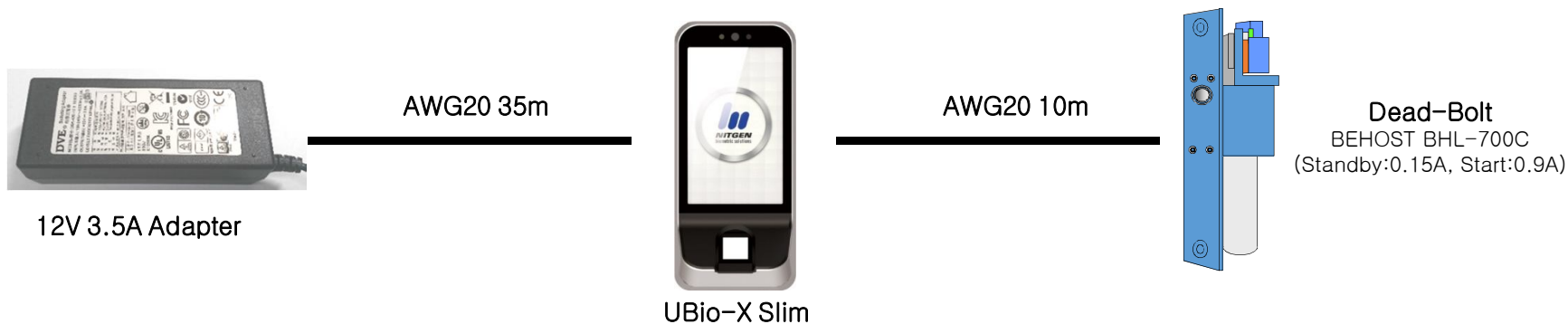

* Caution: The above data are the measured values when using the adapters and the dead-bolts provided by the Union Community.

12. Wiring Guide

12.1 Terminal & Exit Button

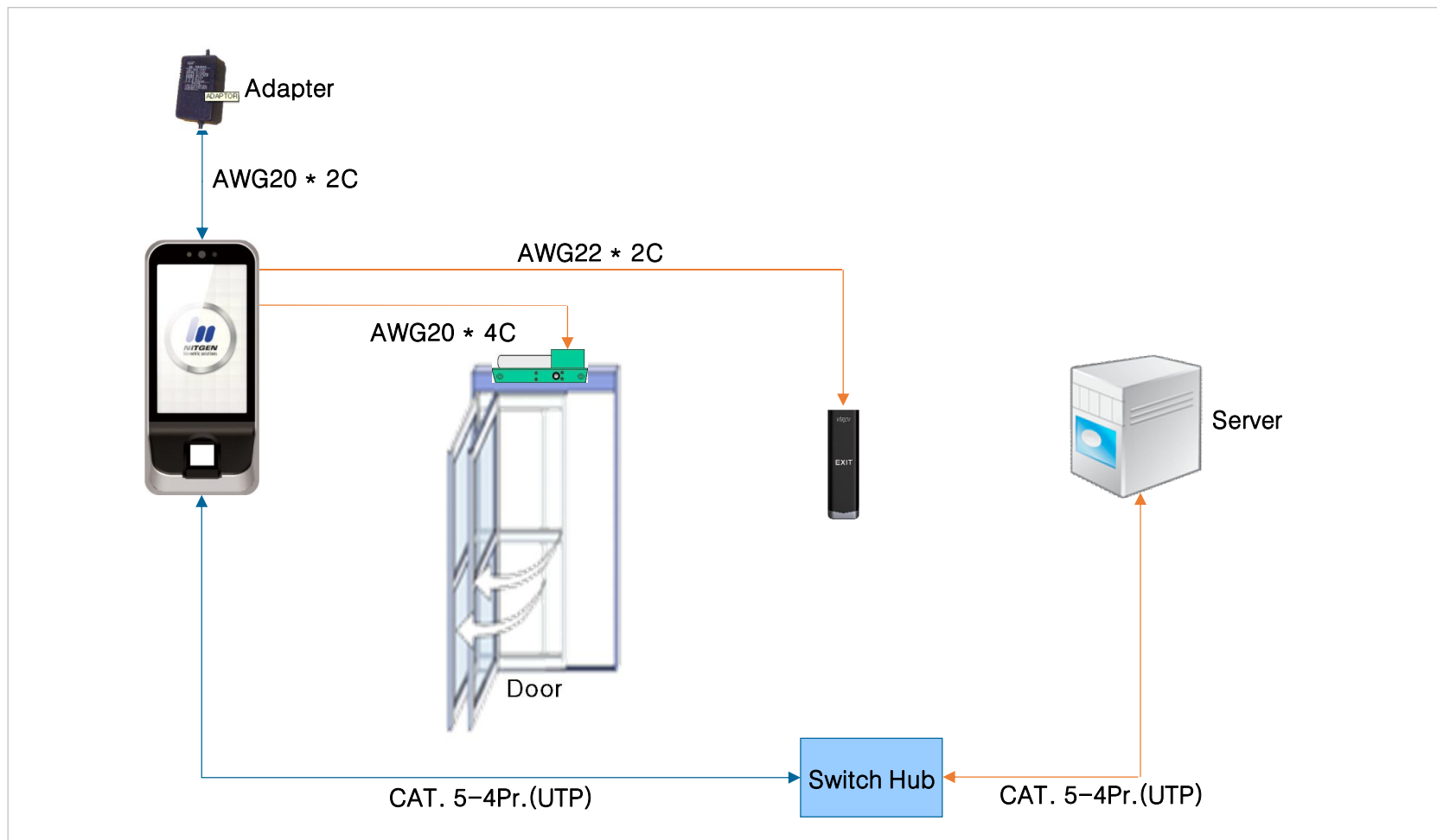

12. Wiring Guide

12.2 Terminal & Exit Button w/Lock Controller

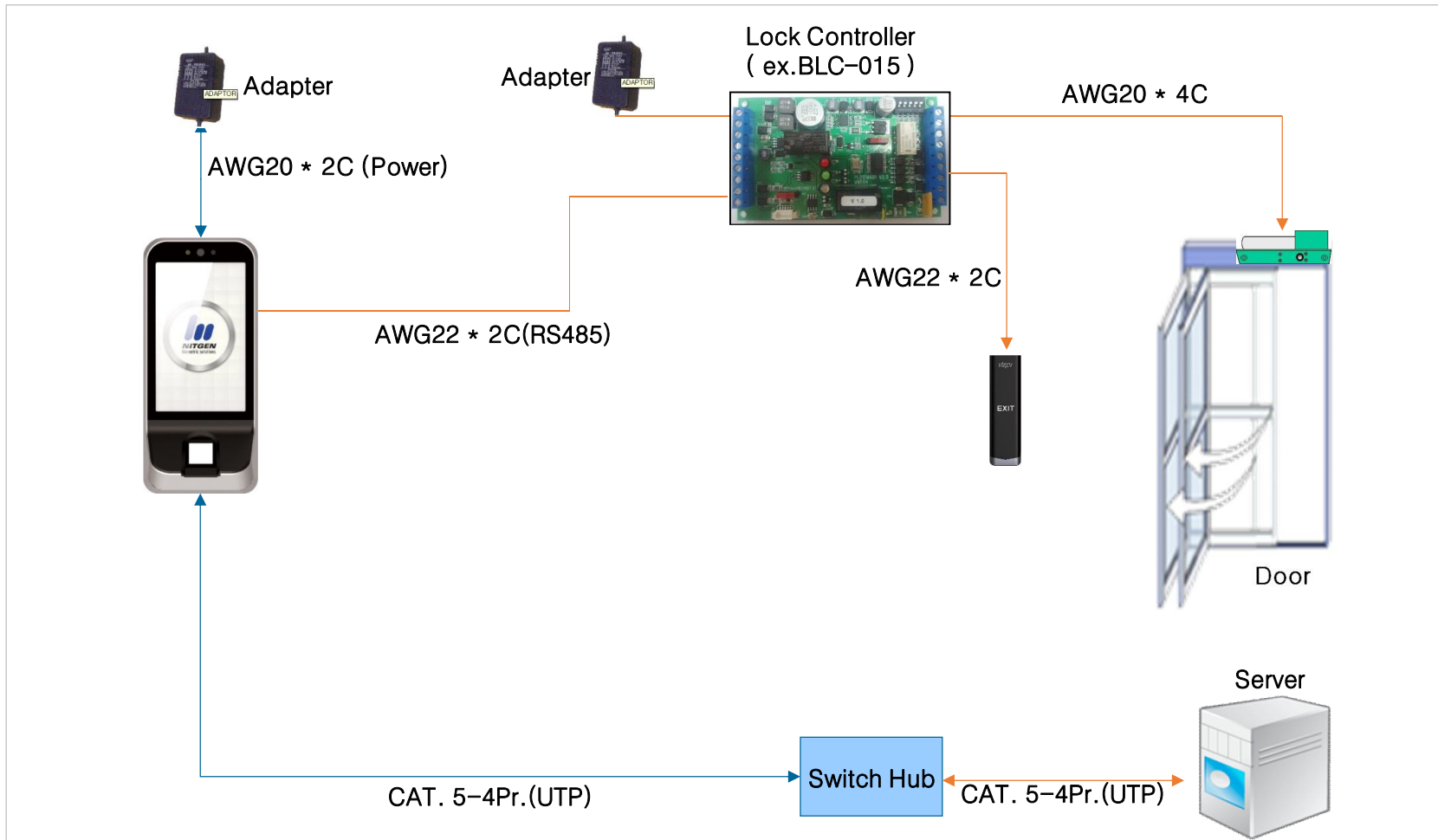

Distributed by



Trading Address: Unit A8 Caxton Point Business Centre, Caxton Point, Caxton Way, Stevenage, SG1 2XU, UK
Registered Office: c/o Becktech Limited, Terminus Road, Chichester, Sussex, PO19 8DW, UK
Telephone: +44 (0)1707 330 541 | Email: sales@genieproducts.co.uk