Installation & Wiring Guide

Card Reader AC1100



Distributed by

genie

*Doc. Ver. : V1.2
June., 18.2019
R&D Center*

1. Cable Descriptions

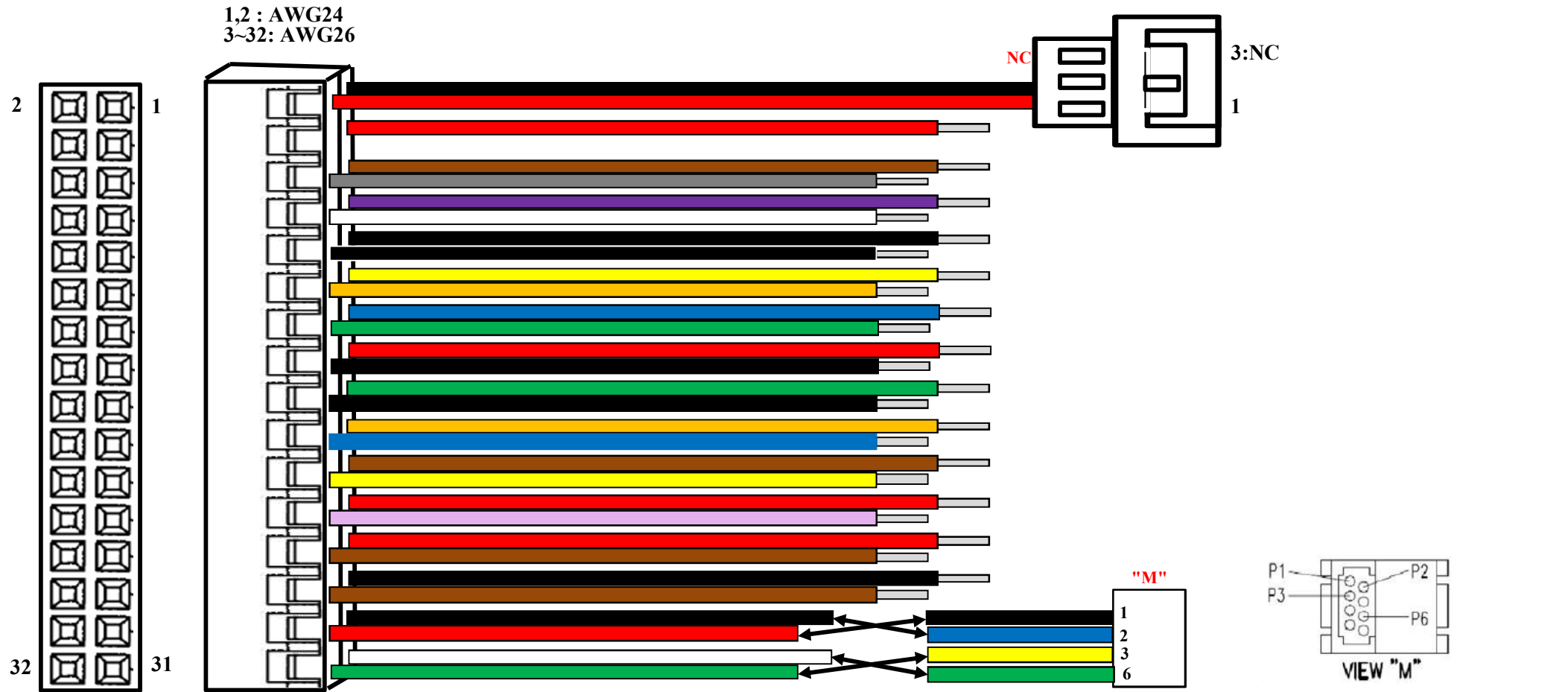

1	Red / 12V IN	9	Black / GND	17	Black / GND	25	Brown / RS232(D) RX
2	Black / GND	10	Black / GND	18	Green / RS485A	26	Red / RS232 TX
3	Not Connected	11	Orange / Exit	19	Blue / RS485B	27	Brown / RS232 RX
4	Red / 12V Out	12	Yellow / Door M0	20	Orange / Wiegand Out0	28	Black / GND
5	Gray / Lock1 COM	13	Green / Door M1	21	Yellow / Wiegand Out1	29	Black(#1,W/O) / ETH TXP
6	Brown / Lock1 NC	14	Blue / Door M2	22	Brown / Wiegand IN0	30	Blue(#2,O) / ETH TXN
7	White / Lock1 NO	15	Black / GND	23	Pink / Wiegand IN1	31	Yellow(#3,W/G) / ETH RXP
8	Violet / Lock2	16	Red / 5V Out	24	Red / RS232(D) TX	32	Green(#6,G) / ETH RXN

2. Schematic for Door Lock Interface

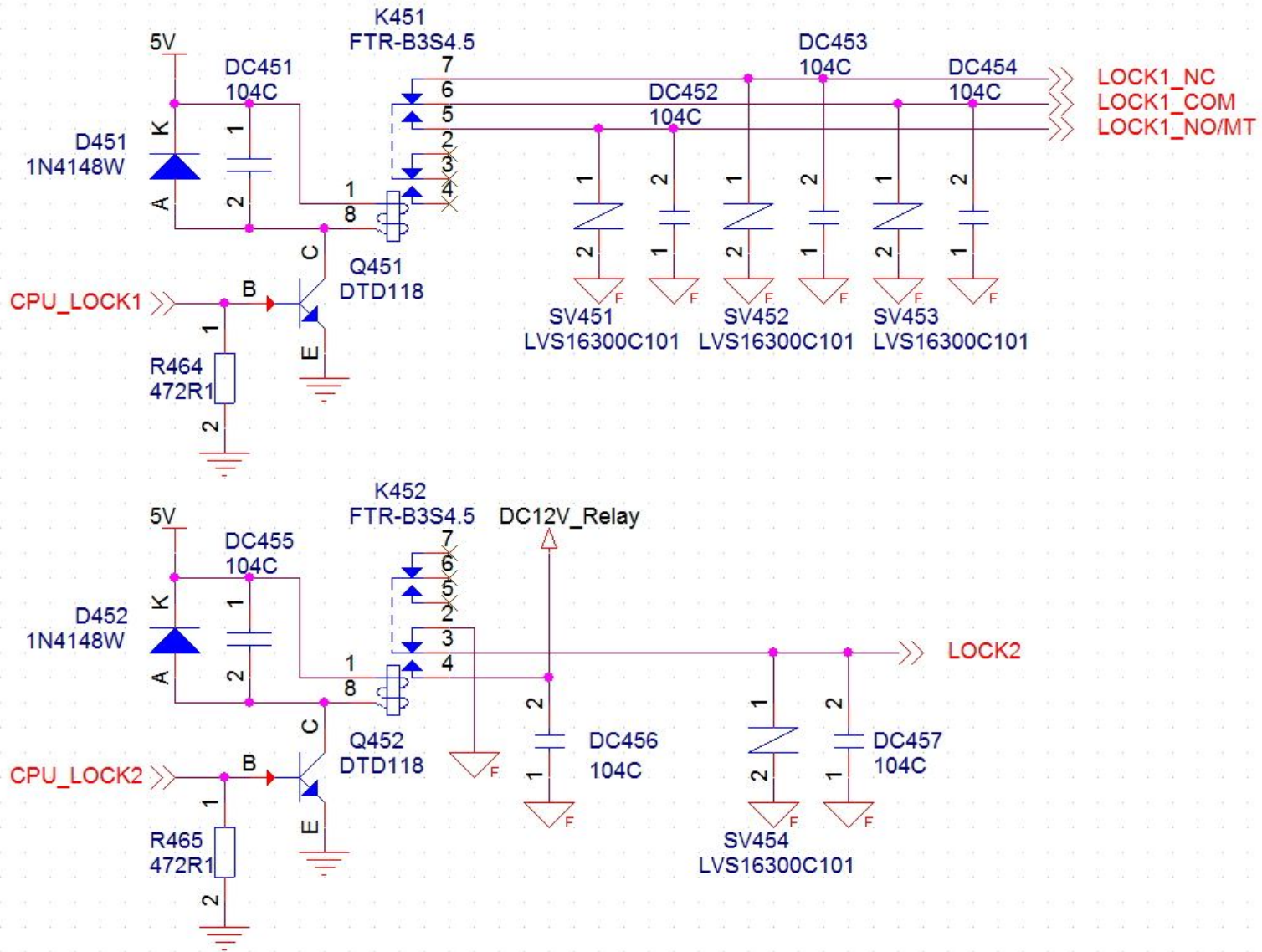

3. Connecting Dead-Bolt Type Door Lock (Fail Safe)

3.1. Connecting One System/ One Lock

<DB Door Signal>
Closed: NO-COM, Short
NC-COM, Open
Opened: NO-COM, Open
NC-COM, Short

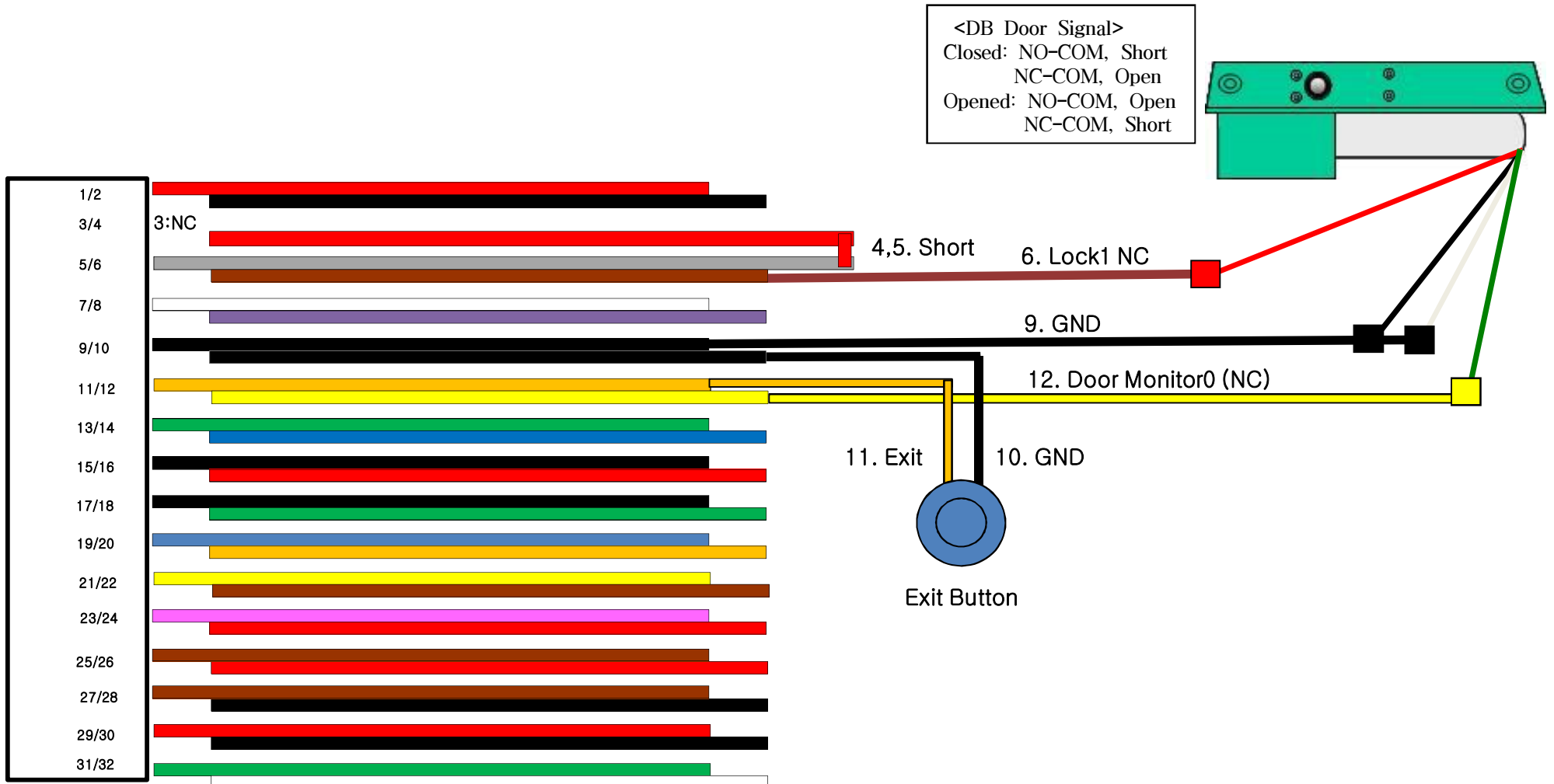

3. Connecting Dead-Bolt Type Door Lock (Fail Safe)

3.2. Connecting Two Systems/ One Lock

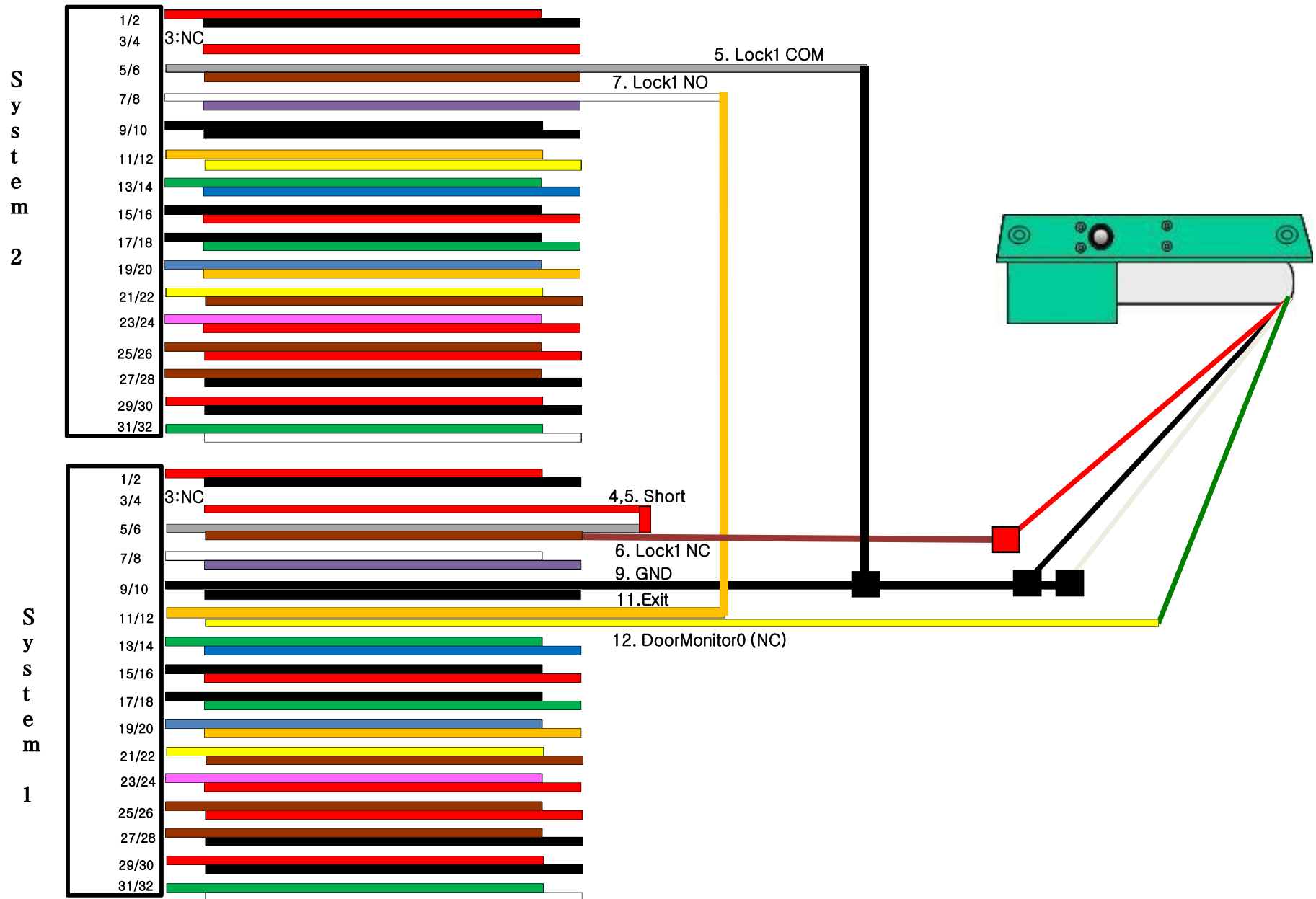

4. Connecting Strike Type Door Lock (Fail Safe)

4.1. Connecting One System/ One Lock

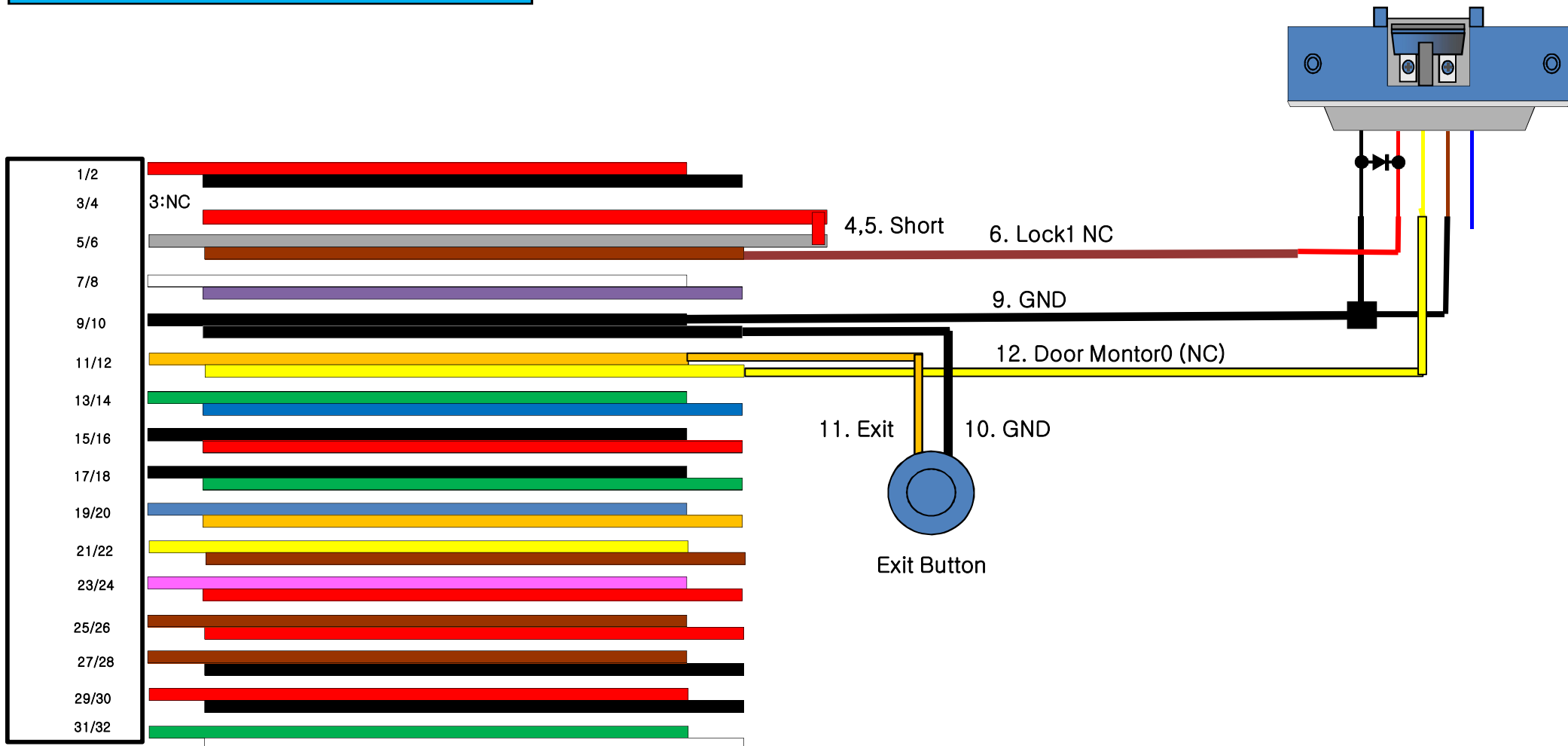

4. Connecting Strike Type Door Lock (Fail Safe)

4.2. Connecting Two Systems/ One Lock

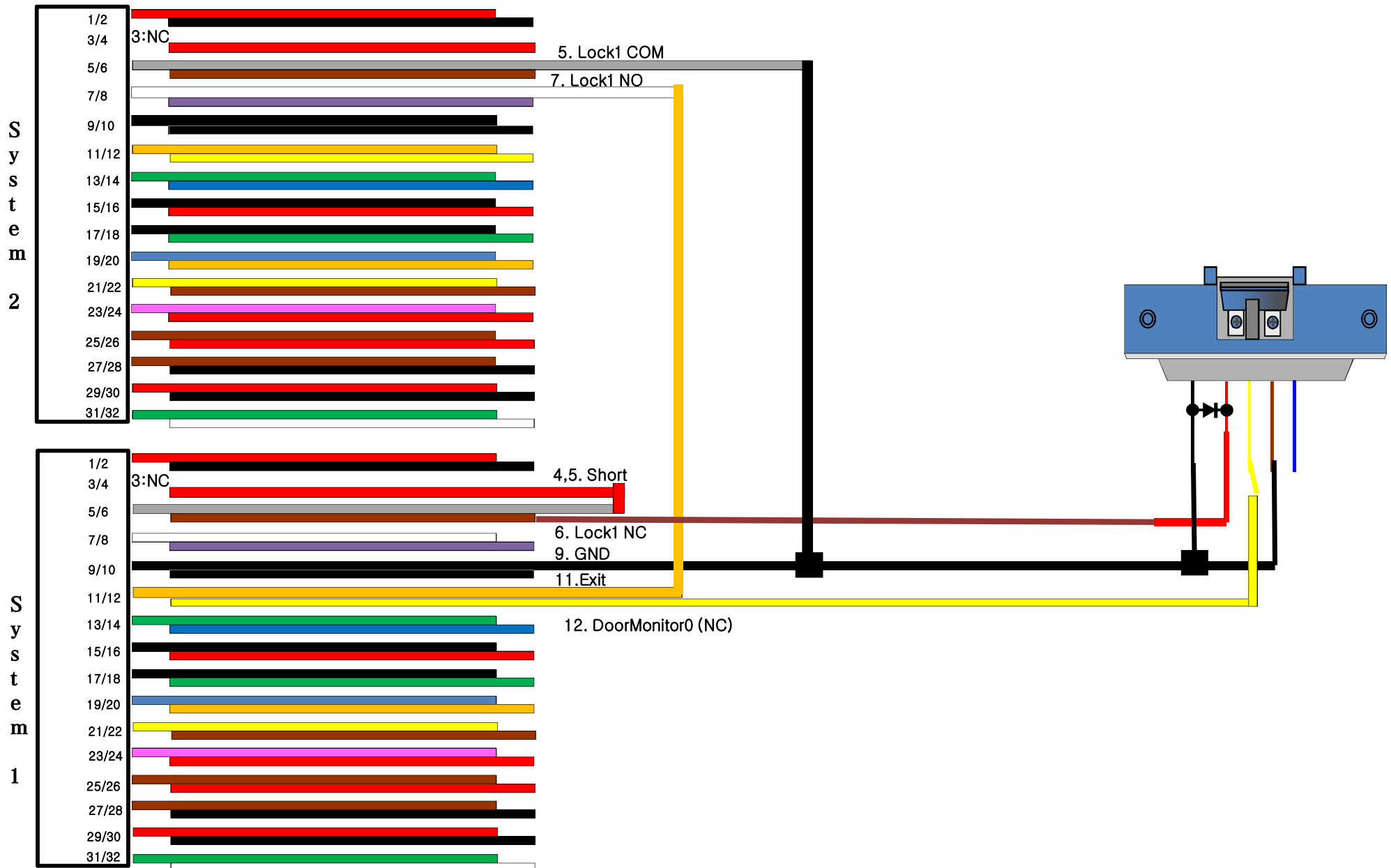

5. Connecting Strike Type Door Lock (Fail Secure)

5.1. Connecting One System/ One Lock

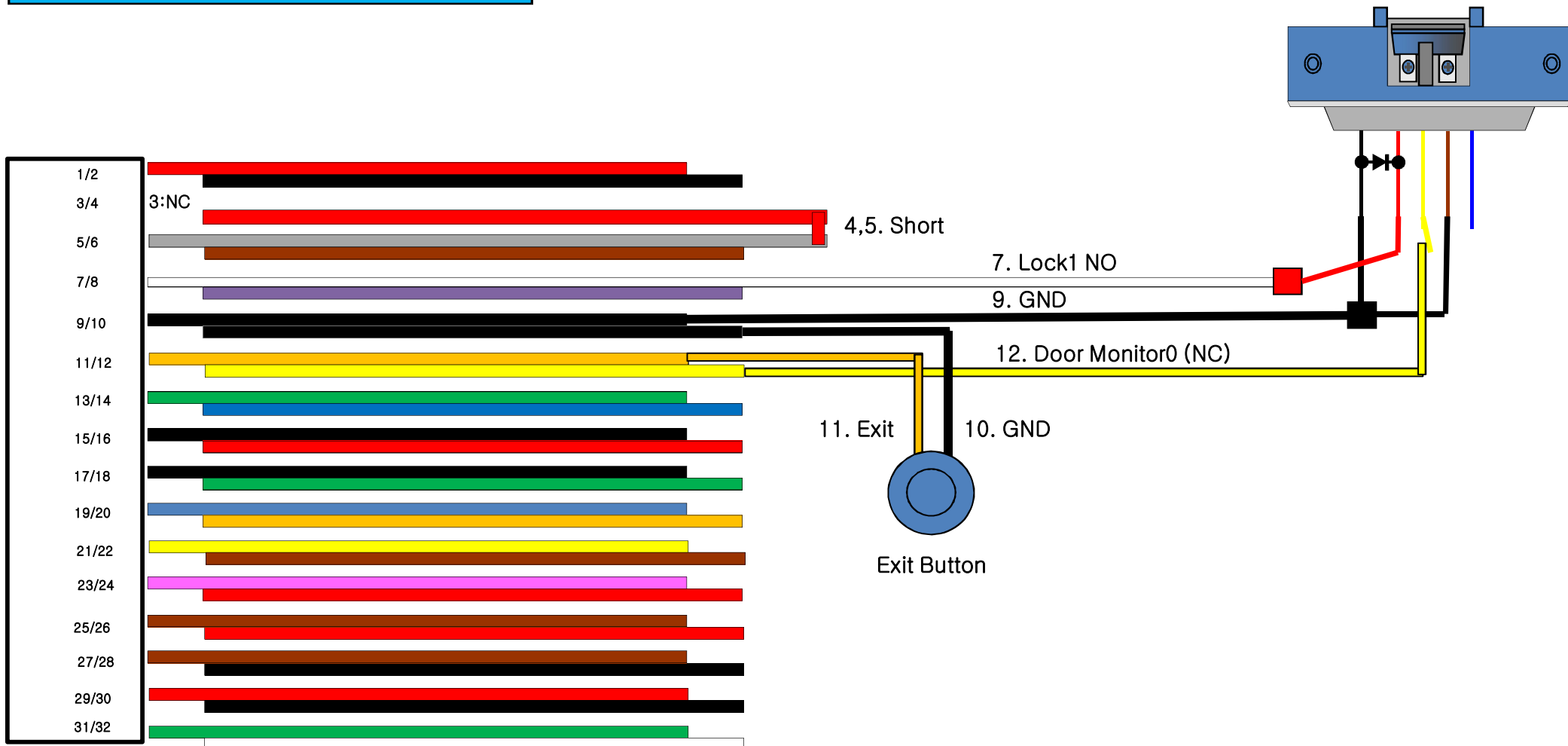

5. Connecting Strike Type Door Lock (Fail Secure)

5.2. Connecting Two Systems/ One Lock

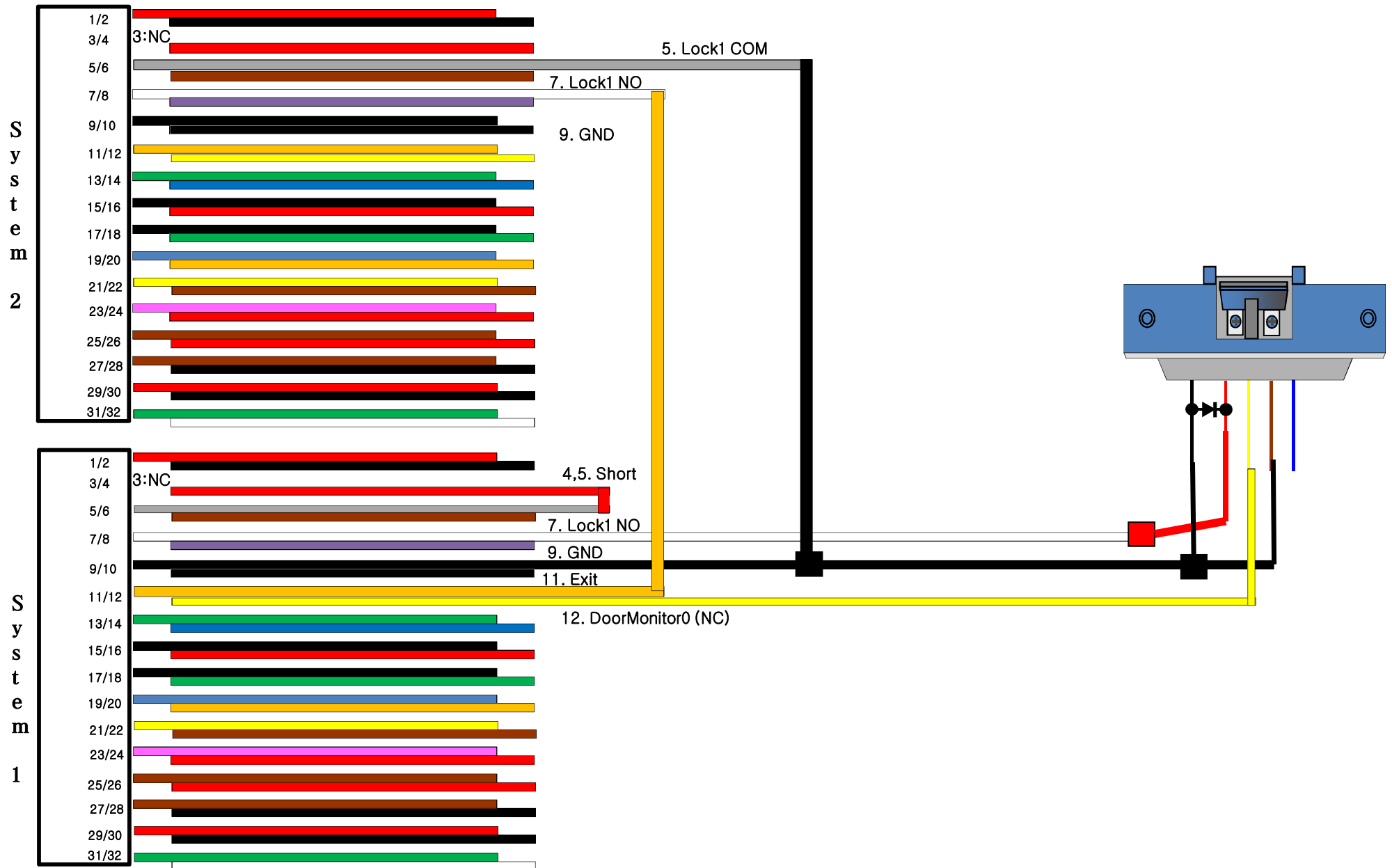

6. Connecting an EM Type Door Lock (Fail Safe)

6.1. Connecting One System/ One Lock

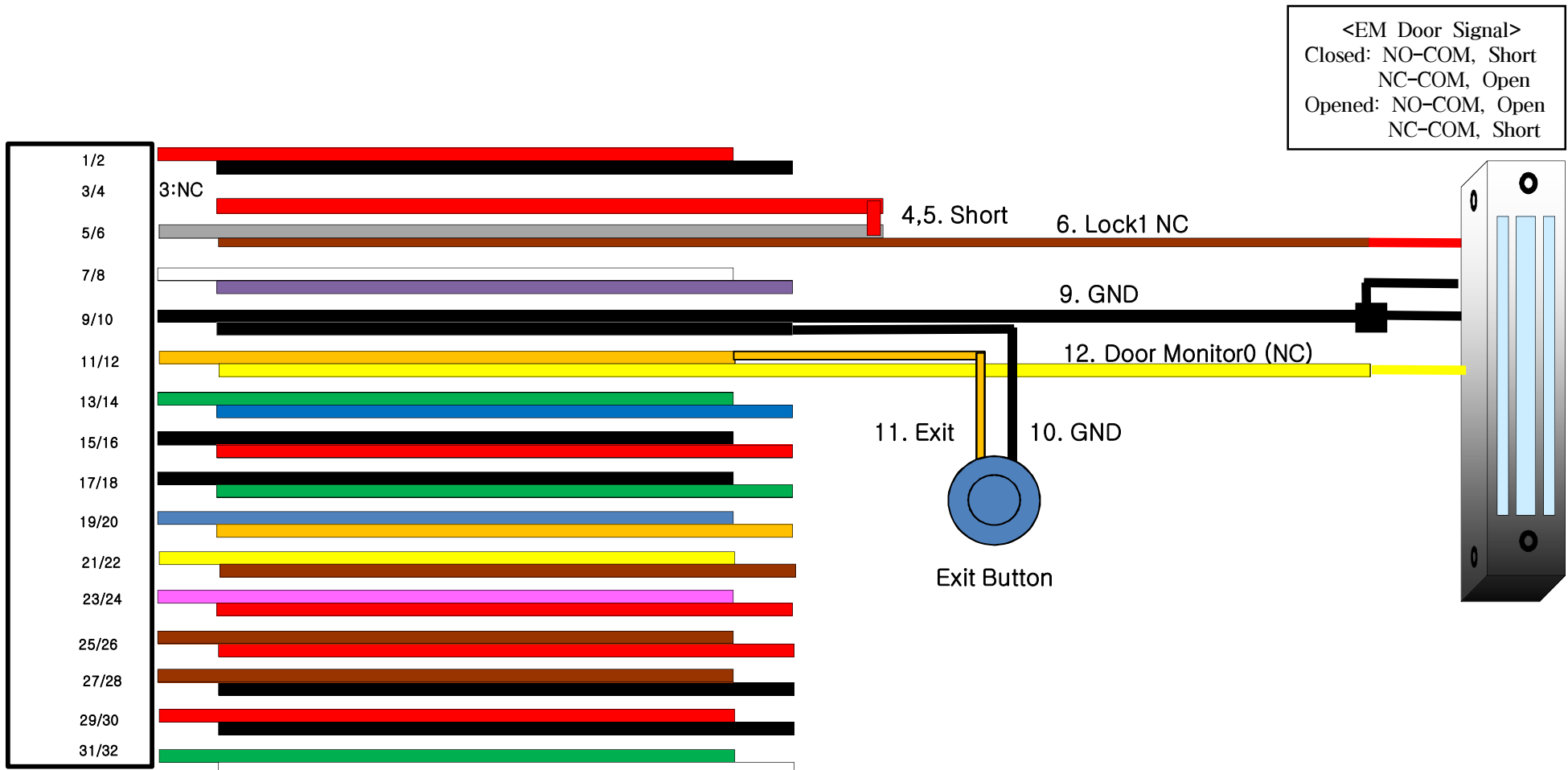

6. Connecting an EM Type Door Lock (Fail Safe)

6.2. Connecting Two Systems/ One Lock

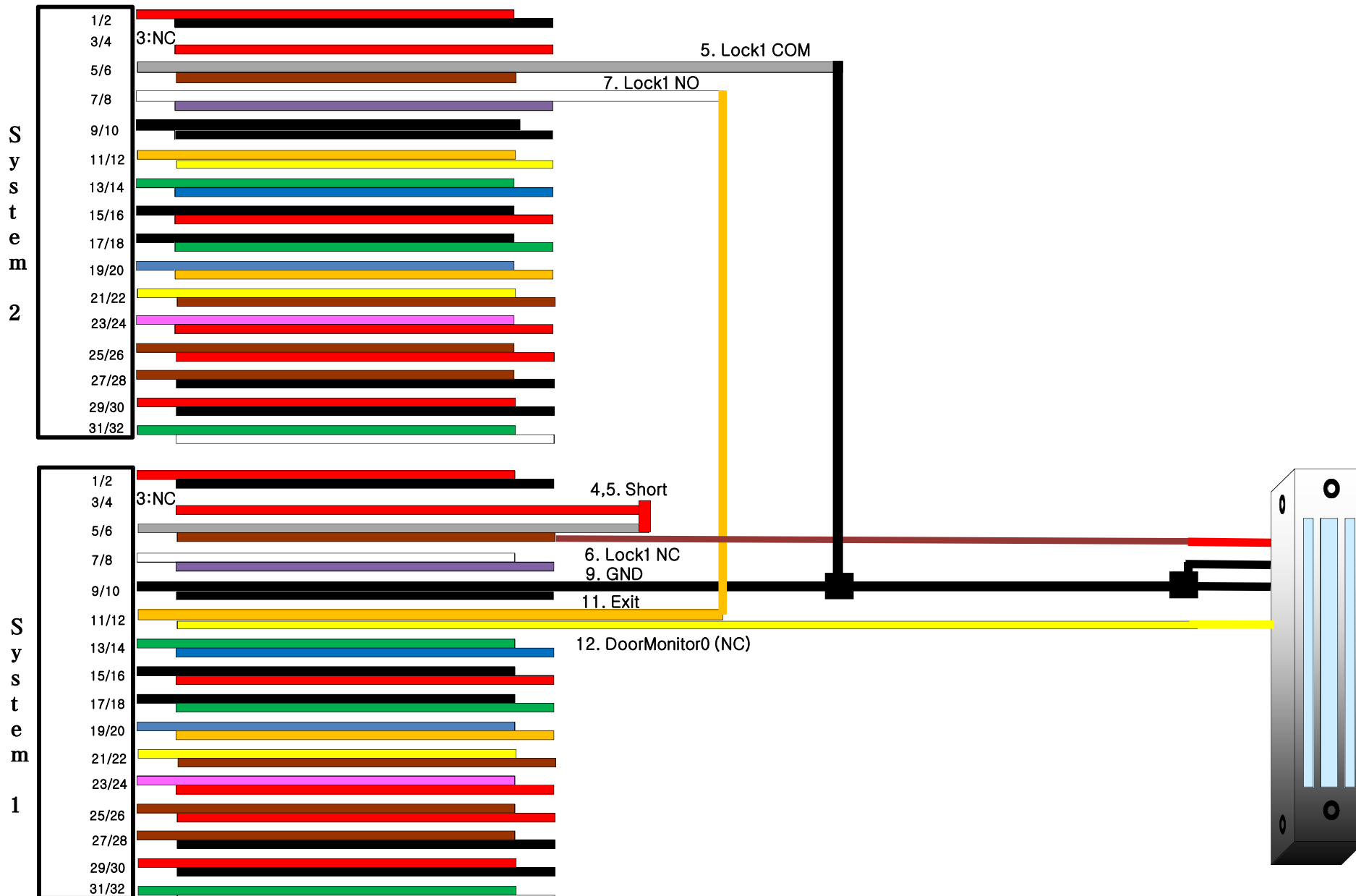

6. Connecting an EM Type Door Lock (Fail Safe)

6.3. Connecting One System/ Two Locks "Use external DC Power adapter"

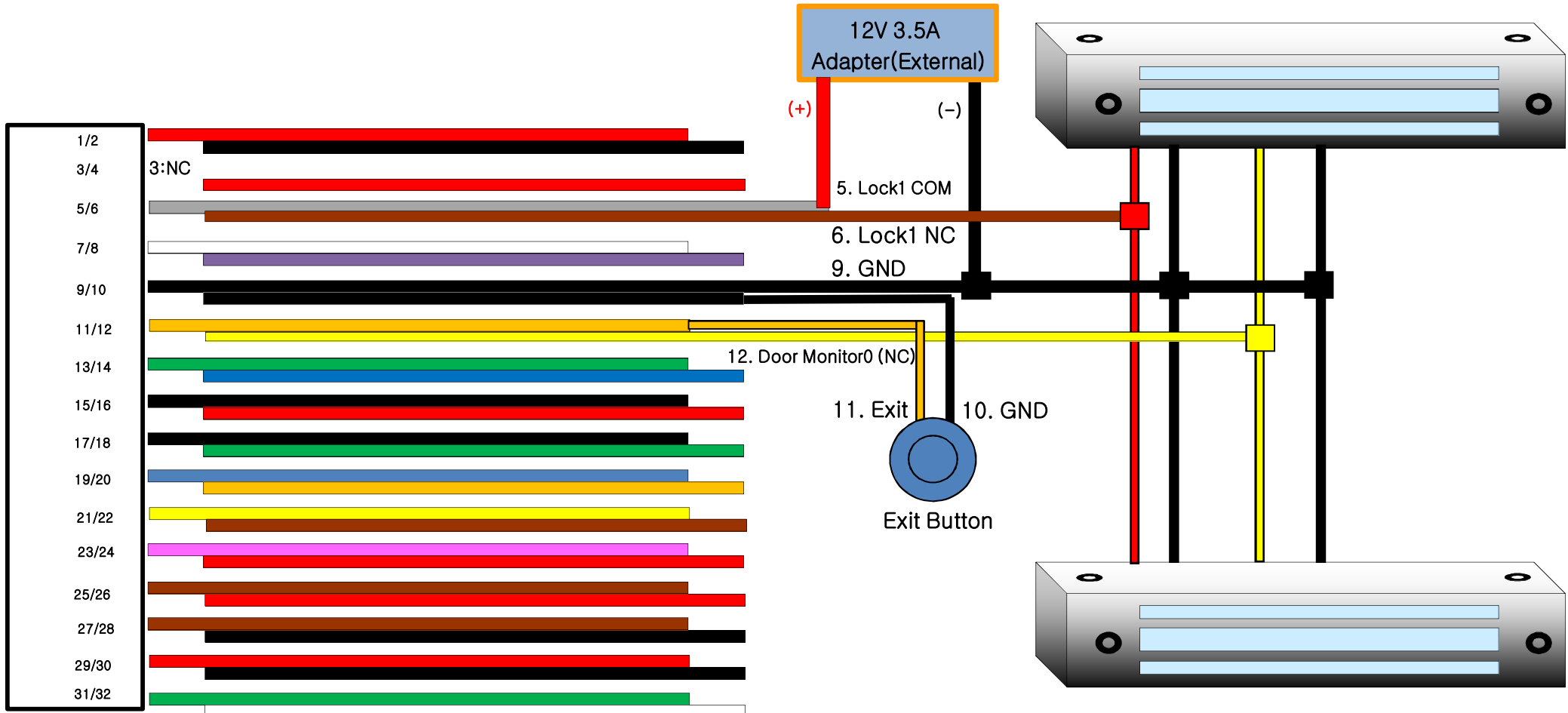

7. Connecting Auto-Door (Contact Control)

7.1. Connecting One System/ One Door

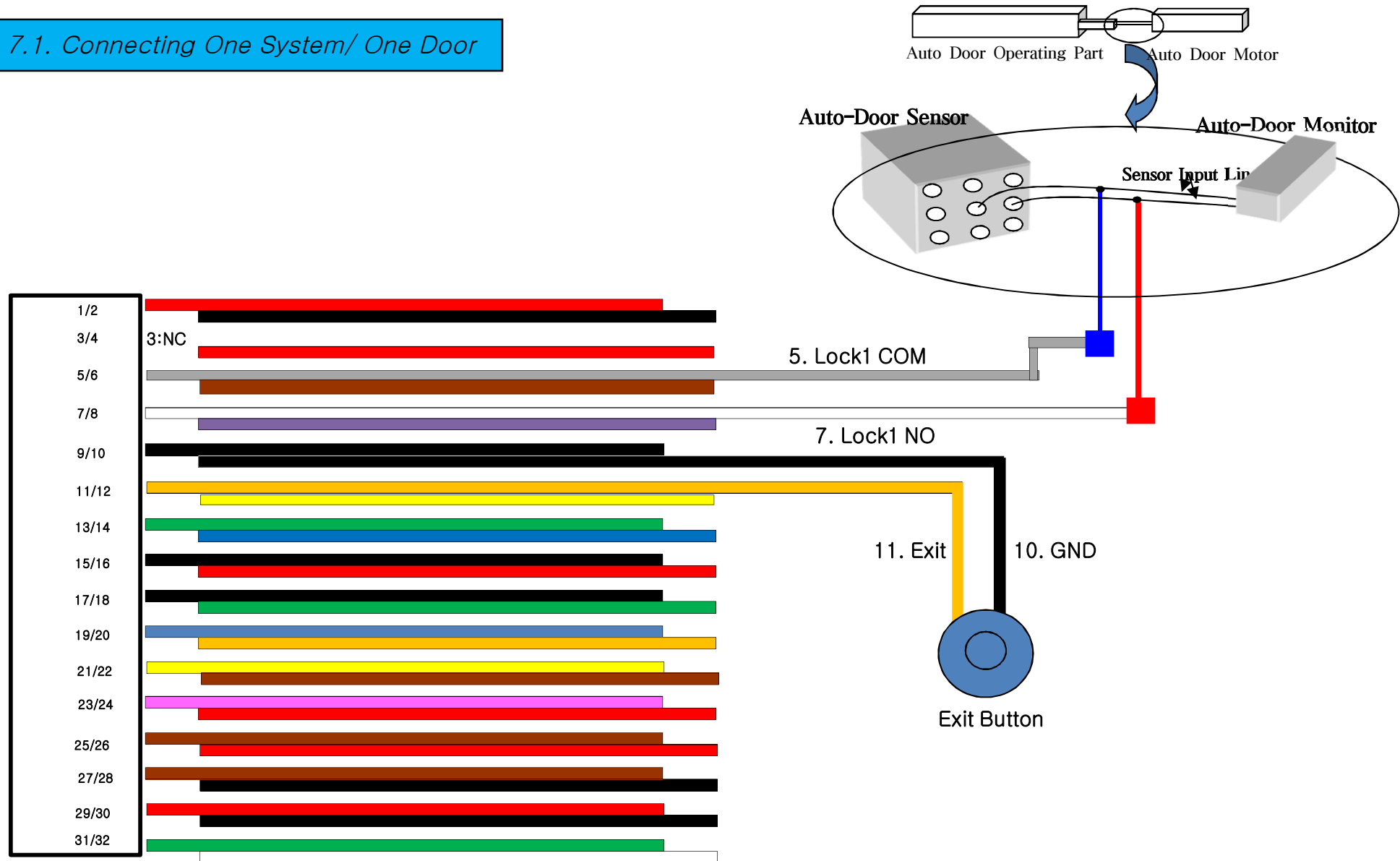

8. Connecting Motorized Lock

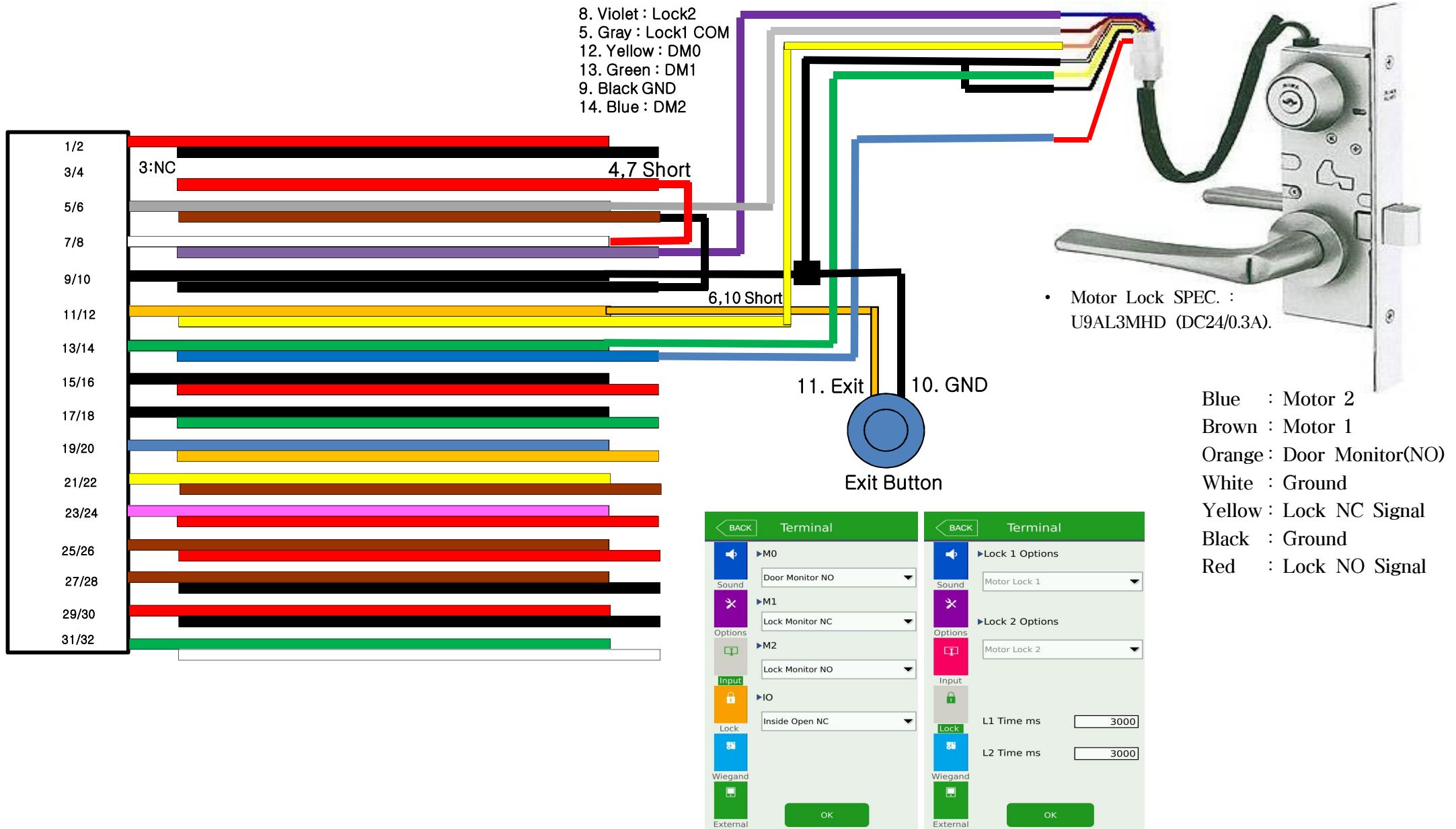

9. Connecting Two Emergency Lamp

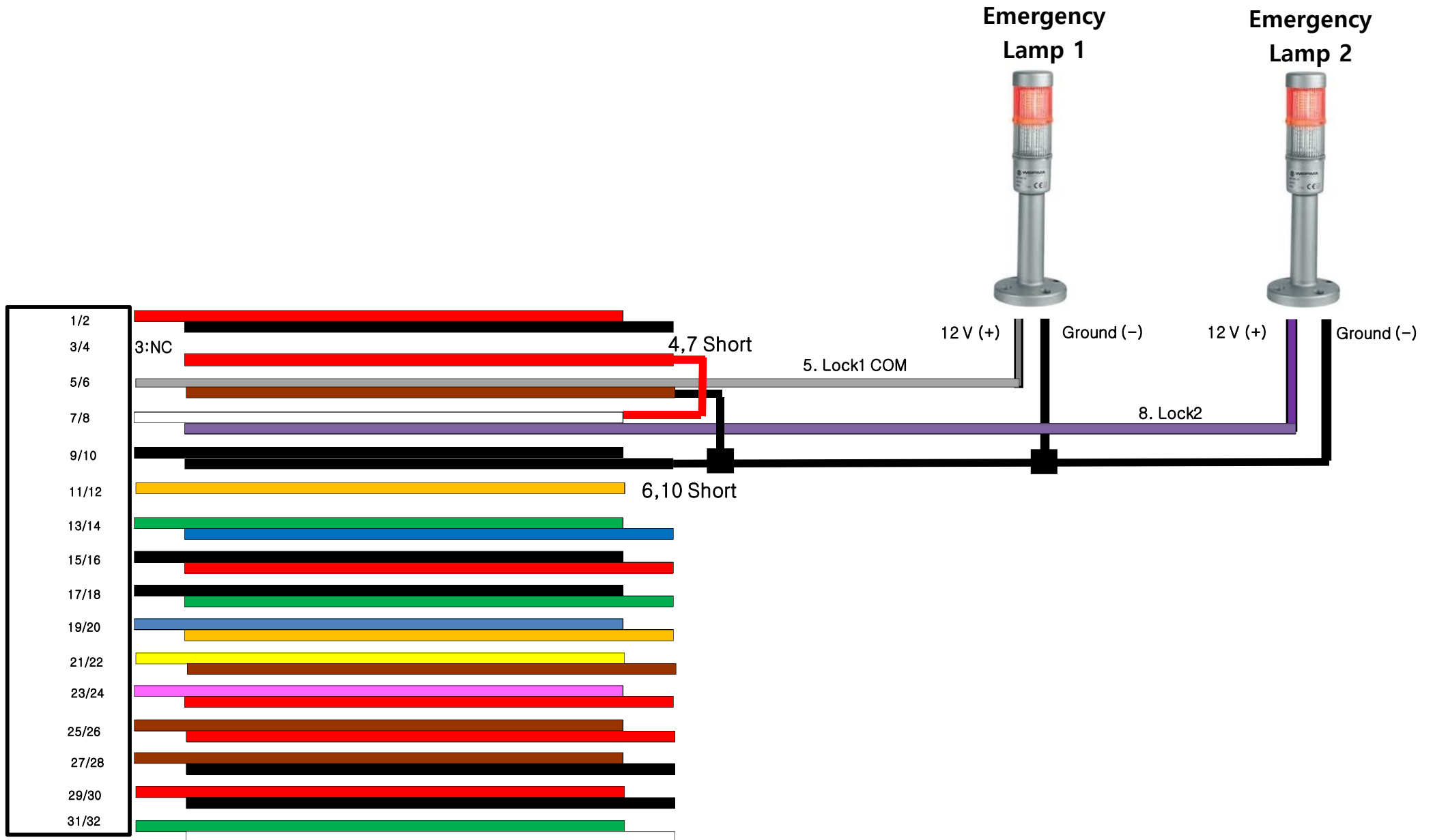

10. Connecting Wiegand IN/OUT to External Controller

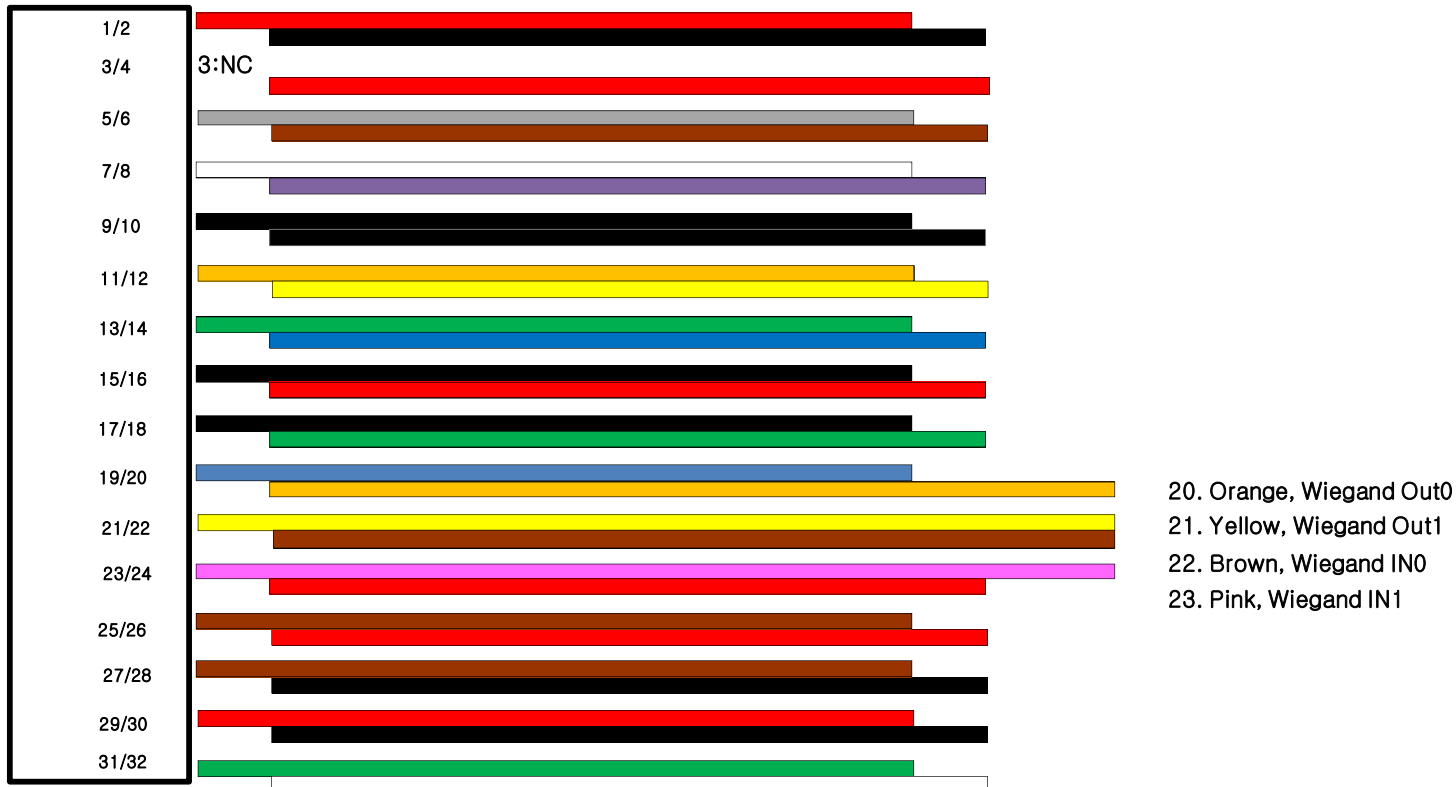

11. Connecting RS232 TX/RX to External Printer

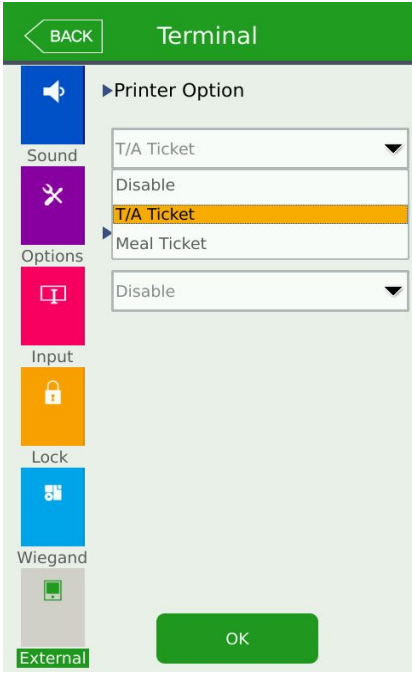
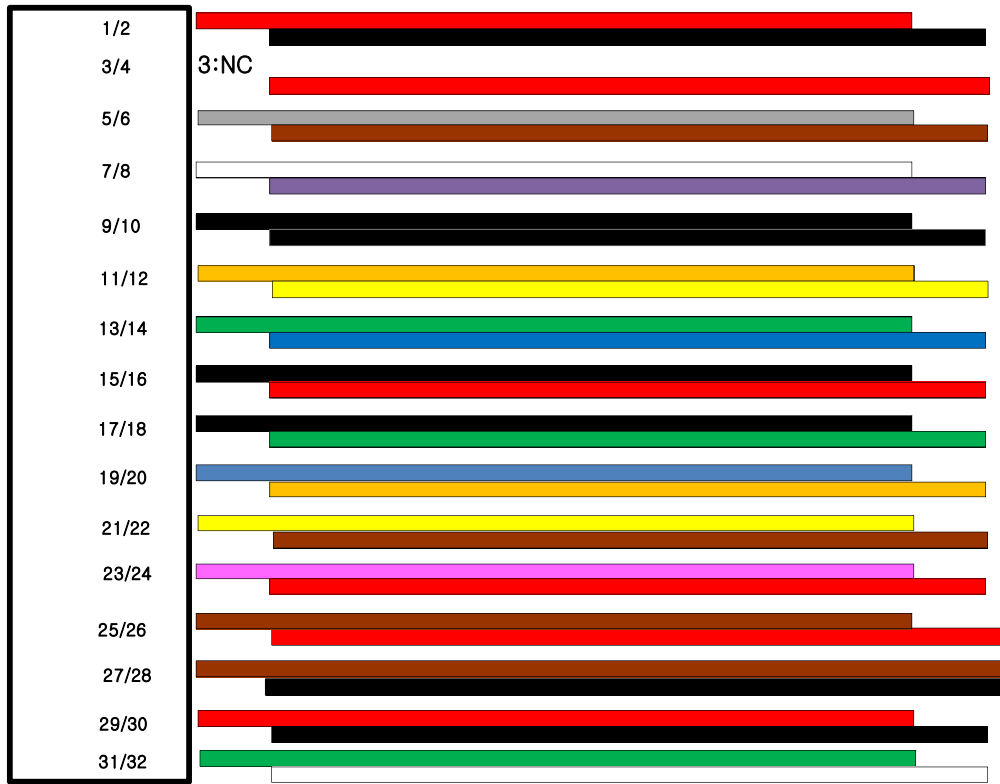

Set Printer Option:
 T/A Ticket or
 Meal Ticket
 Note: Application mode
 must be set for T/A or
 Meal as well.

26. Red, RS232 TX
 27. Brown, RS232 RX
 28. GND

Serial Printer
 SRP500

12. Resistor Setting for RS485 End Termination

12.1 External 120Ω Resistor is not connected between 485A and 485B. (Default Setting)

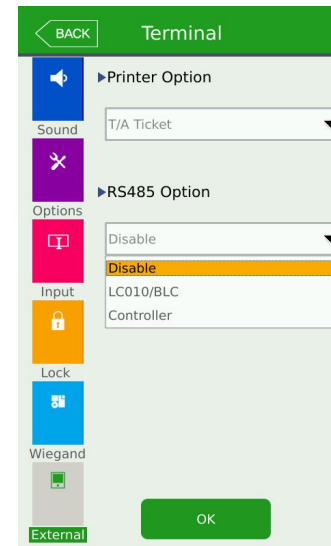
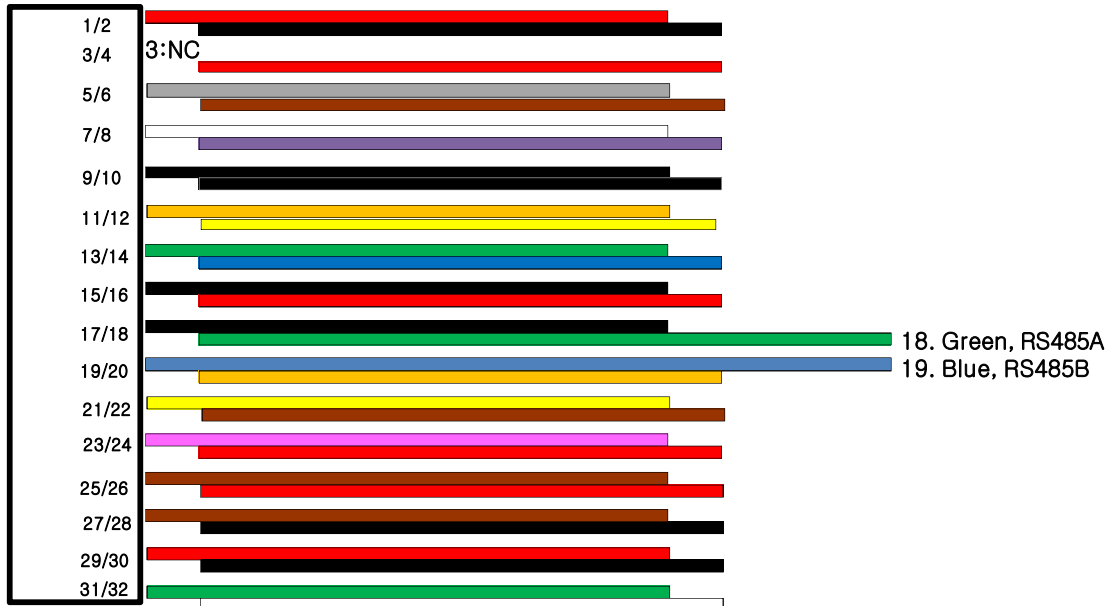

Set the RS485 Option to:
LC010/BLC or
Controller (MCP)

12.2 External 120Ω Resistor is connected between 485A and 485B.

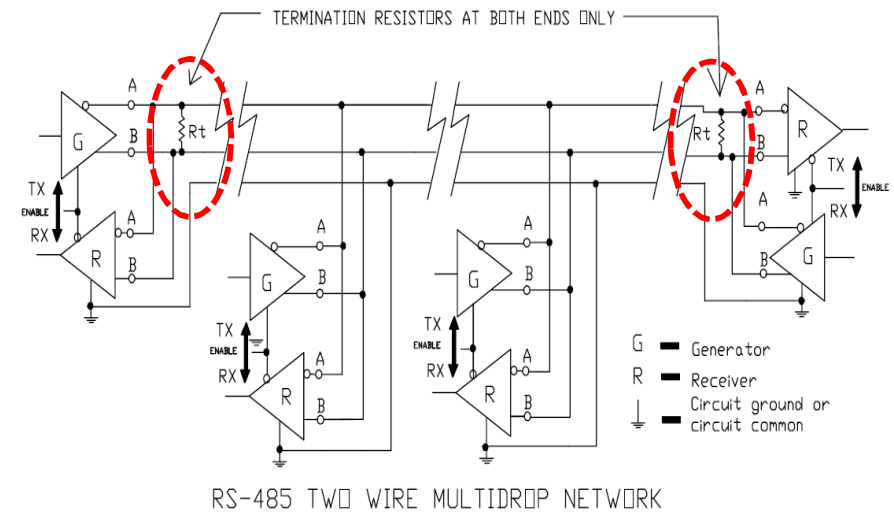
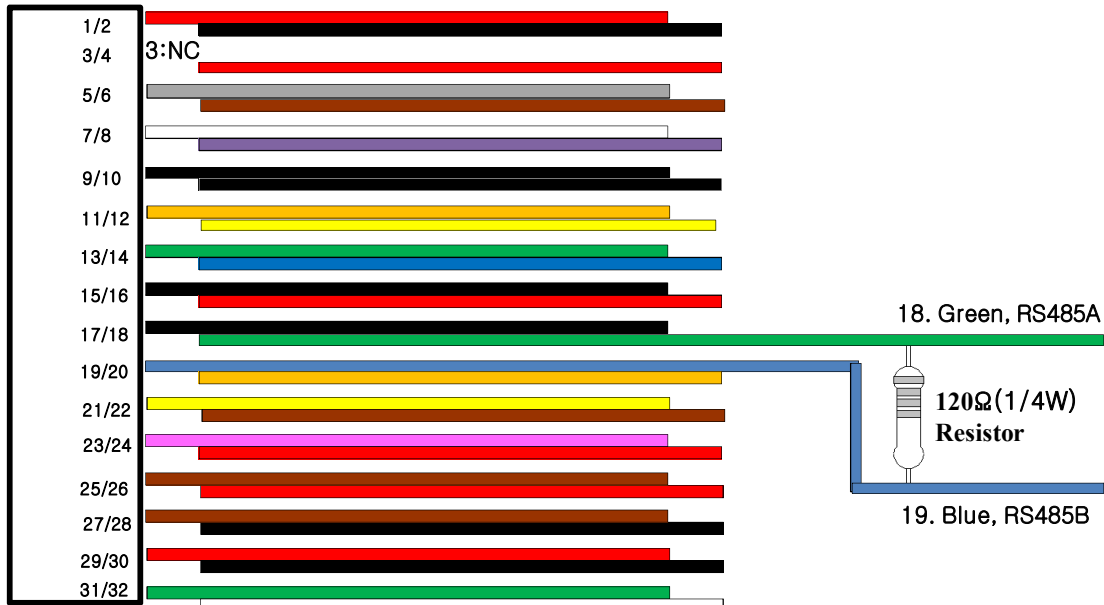

13. Wiring Guide

13.1 Terminal & Exit Button

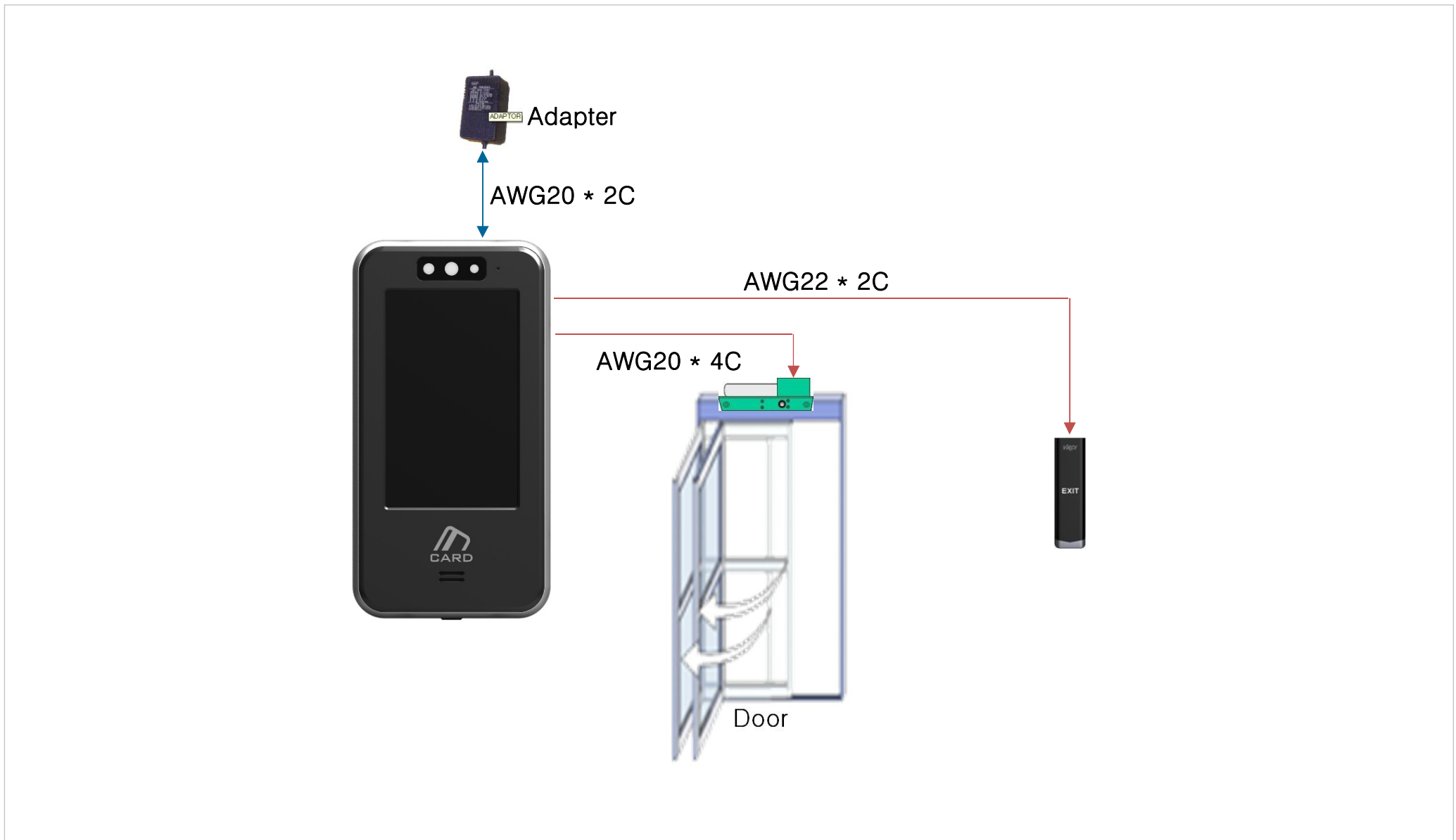

14. Appendix

14.1 How to connect an external relay

** It is recommended to connect an external relay if a problem occurs after connection with an external equipment such as a speed gate.

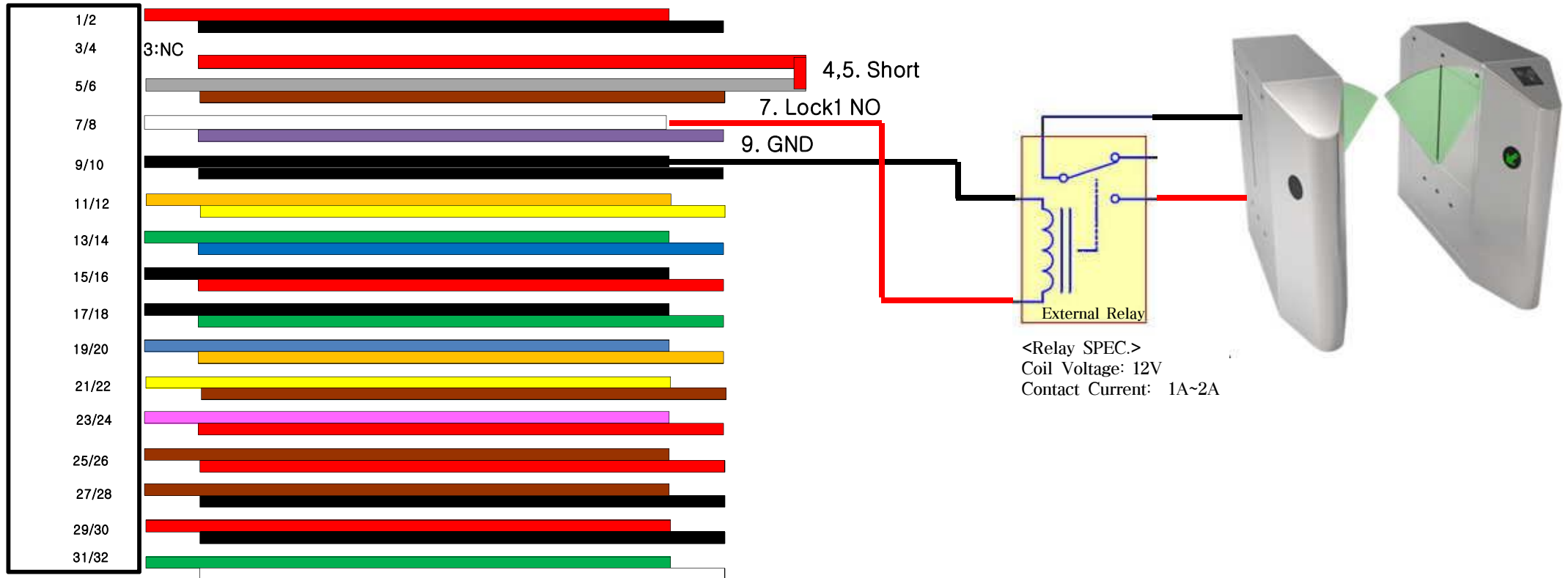

14. Appendix

14.2 How to connect the VS-R20D RF Dummy Card Reader

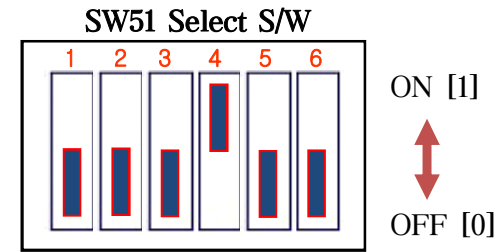

- * 1, 2, 3 OFF: 26Bit
- * 4 ON: Wiegand Mode

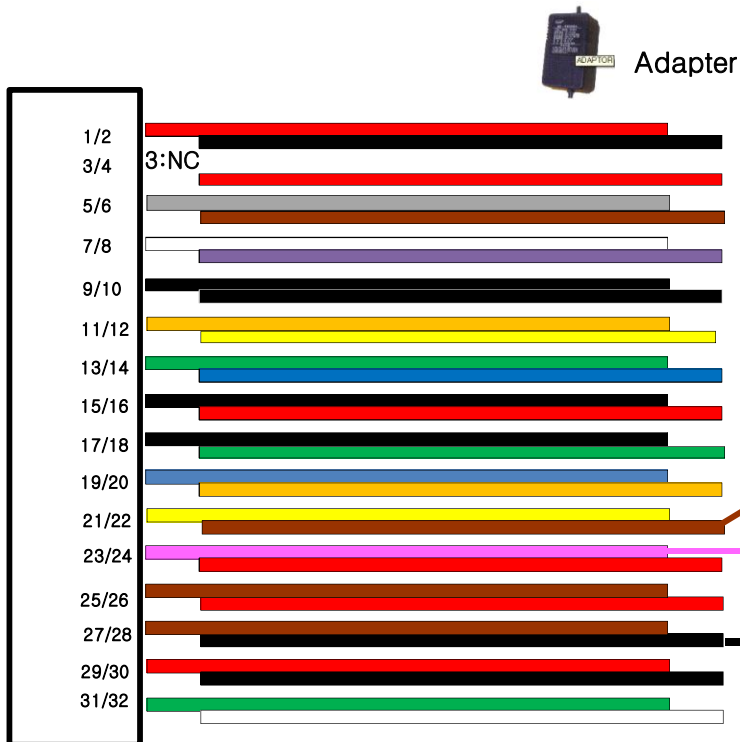

- 1 : RED : +12V INPUT
- 2 : Black : Power Ground
- 3 : Green : RS-485 A
- 4 : Blue : RS-485 B
- 5 : Black : Power Ground
- 6 : Orange : Wiegand Out 0
- 7 : Yellow : Wiegand Out 1
- 8 : Brown : 232TXD (3.3V - TTL level)
- 9 : Gray : 232RXD (3.3V - TTL level)

14. Appendix

14.3 How to connect the VS-R20D SC Dummy Card Reader

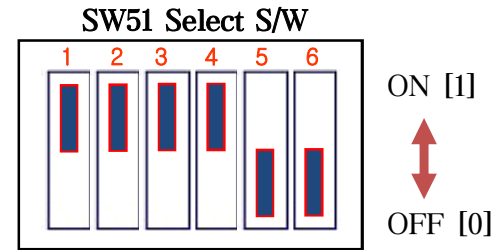

- * 1, 2, 3 ON: 34Bit
- * 4 ON: Wiegand Mode

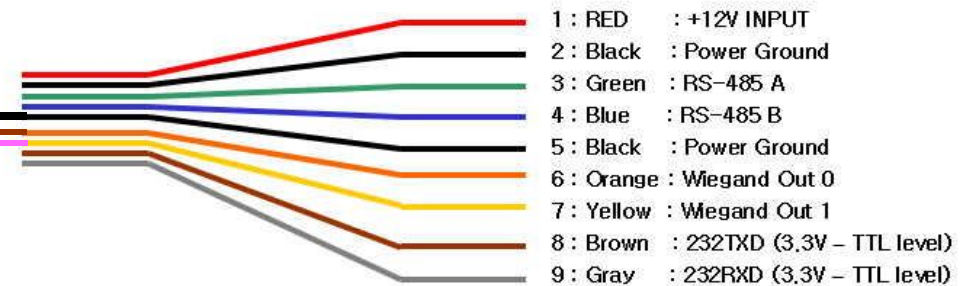
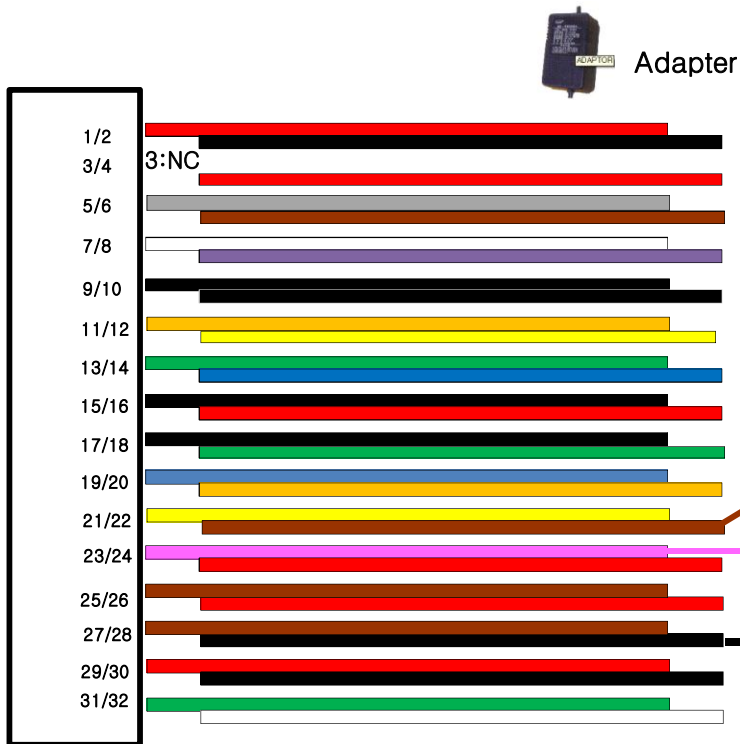

Distributed by



Trading Address: Unit A8 Caxton Point Business Centre, Caxton Point, Caxton Way, Stevenage, SG1 2XU, UK
Registered Office: c/o Becktech Limited, Terminus Road, Chichester, Sussex, PO19 8DW, UK
Telephone: +44 (0)1707 330 541 | Email: sales@genieproducts.co.uk