Installation & Wiring Guide

FingerPrint Terminal

AC-2000 & AC-2100PLUS

Distributed by



Doc. Ver. : V1.1

JUN.,24.2019

R&D Center

Union Community Co., Ltd.

1. Cable Descriptions



- 1. Orange : EXIT : EXT
- 2. Yellow : DM0 : DM0
- 3. Green : DM1 : DM1
- 5. Black : Gnd : GND
- 6. Red : 5V : 5V
- 7. Black : Gnd : GND
- 8. Green : RS485A : R4A
- 9. Blue : RS465B : R4B

- 10. Orange : WieOut0 : WO0
- 11. Yellow : WieOut1 : WO1
- 12. Brown : WieIN0 : WI0
- 13. Pink : WieIN1 : WI1
- 14. Black : Gnd : GND
- 15. Black : E_TXP
- 16. Blue: E_TXN
- 17. Yellow : E_RXP
- 18. Green : E_RXN
- 19. Red : 12V IN : 12V
- 20. Black : Gnd : GND

- 21.Red : 12V Out : 12V
- 22.Gray : Lock 1 Com : L1C
- 23.Brown : Lock 1 NC : L1NC
- 24.White : Lock 1 NO : L1NO
- 26. Black : Gnd : GND
- 27. Black : Gnd : GND
- 28. Black : Gnd : GND

H3	Color	H1
P1	Black	I5
P2	Blue	I6
P3	Yellow	I7
P4	-	-
P5	-	-
P6	Green	I8
P7	-	-
P8	-	-

2. Schematic for Door Lock Interface

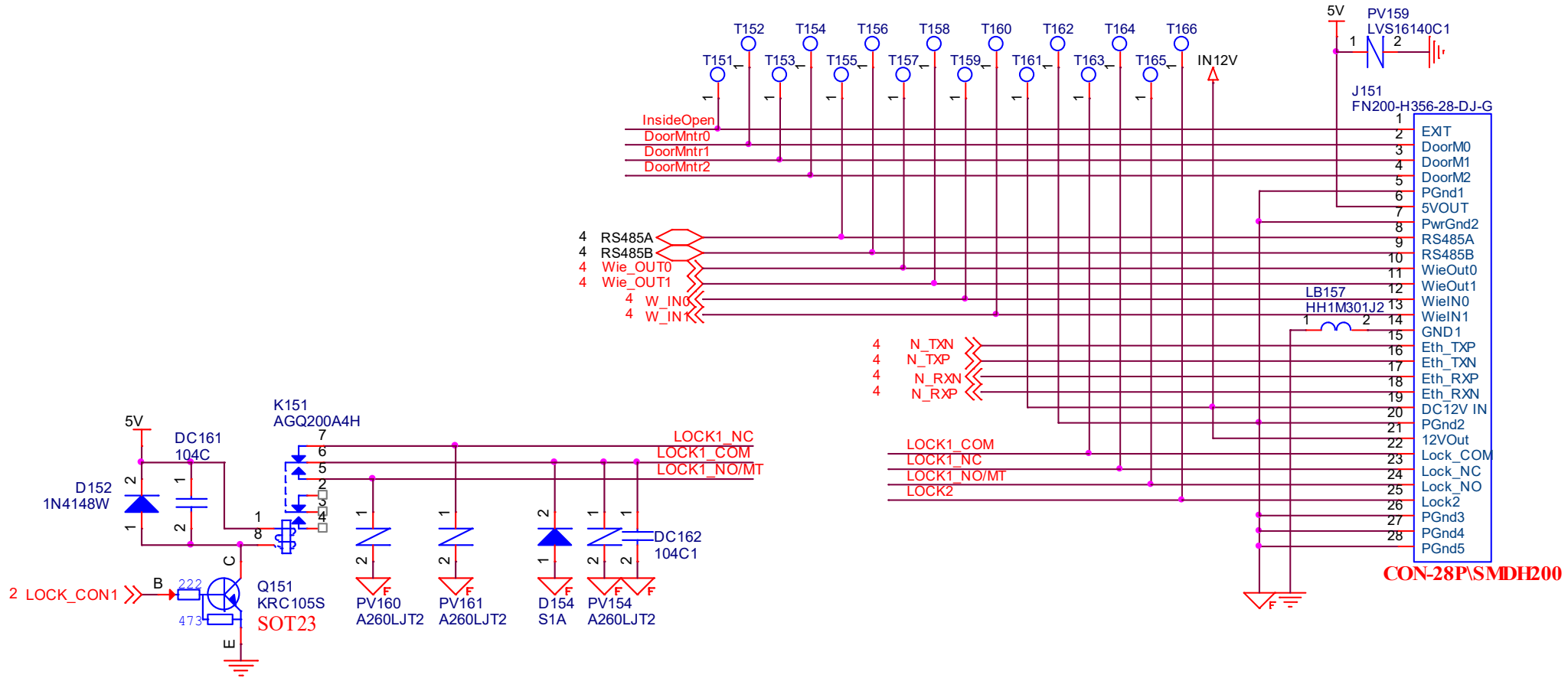

3. Connecting Dead-Bolt Type Door Lock (Fail Safe)

3.1. Connecting One System/ One Lock

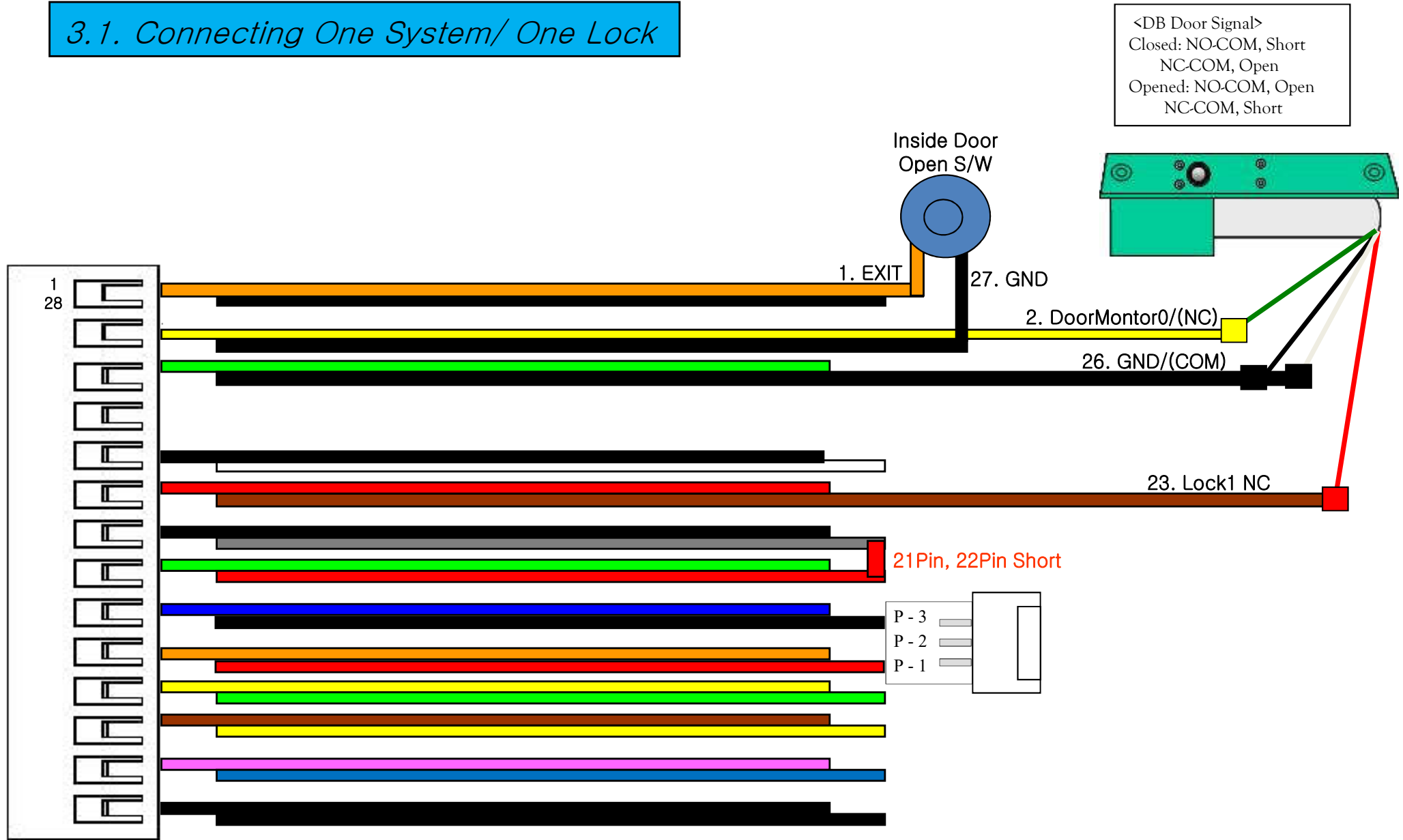

3. Connecting Dead-Bolt Type Door Lock (Fail Safe)

3.2. Connecting Two Systems/ One Lock

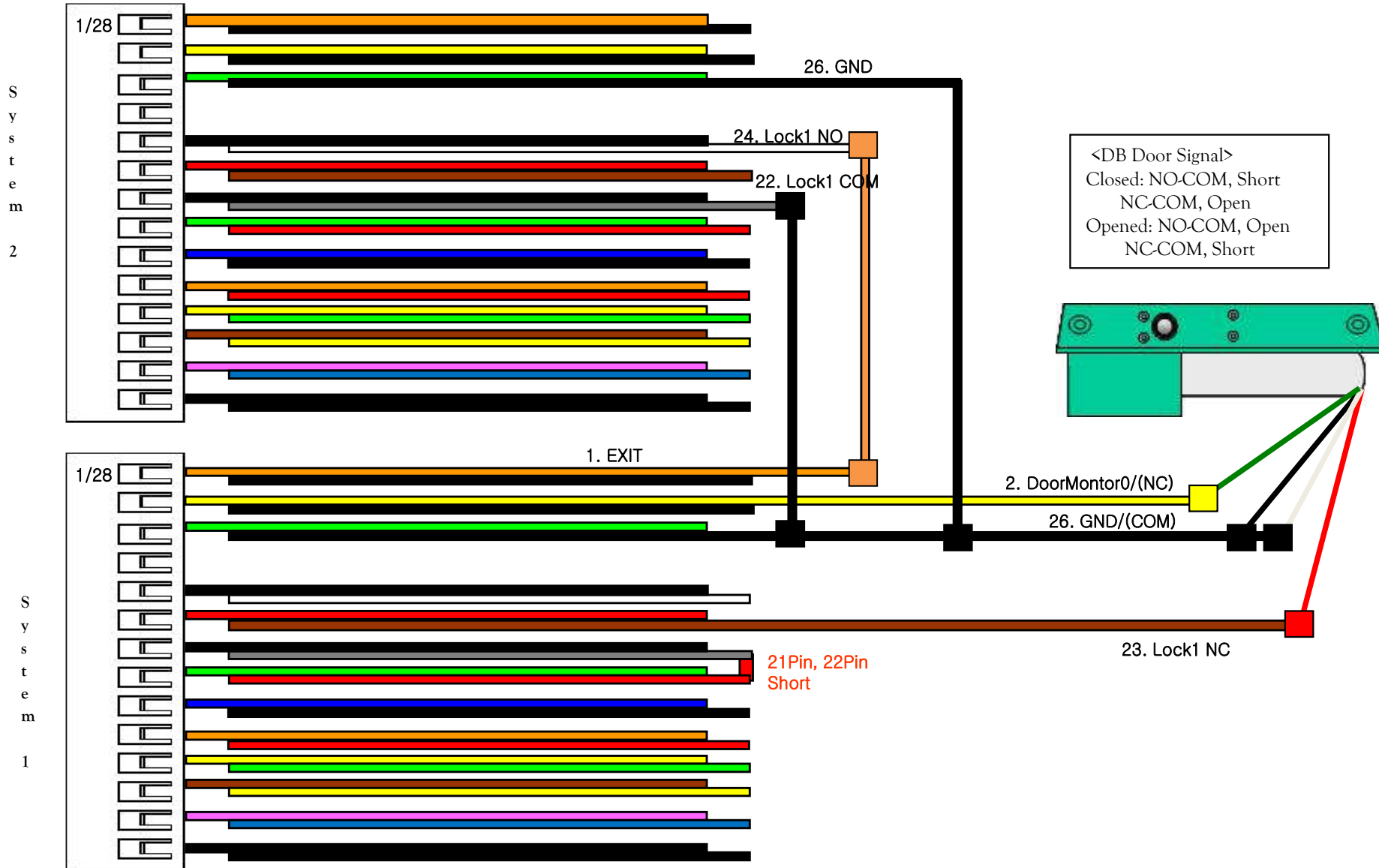

4. Connecting Strike Type Door Lock (Fail Safe)

4.1. Connecting One System/ One Lock

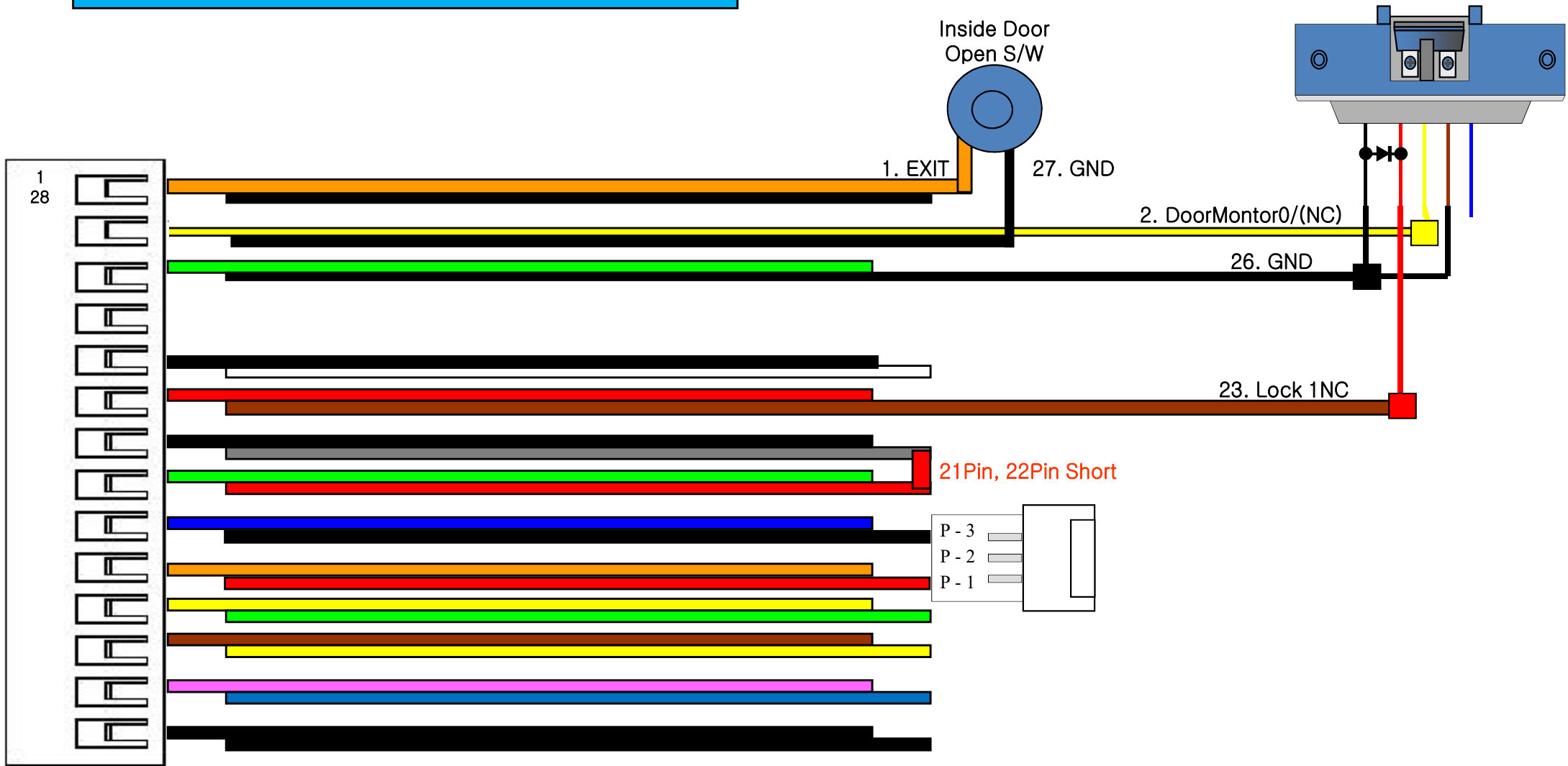

4. Connecting Strike Type Door Lock (Fail Safe)

4.2. Connecting Two Systems/ One Lock

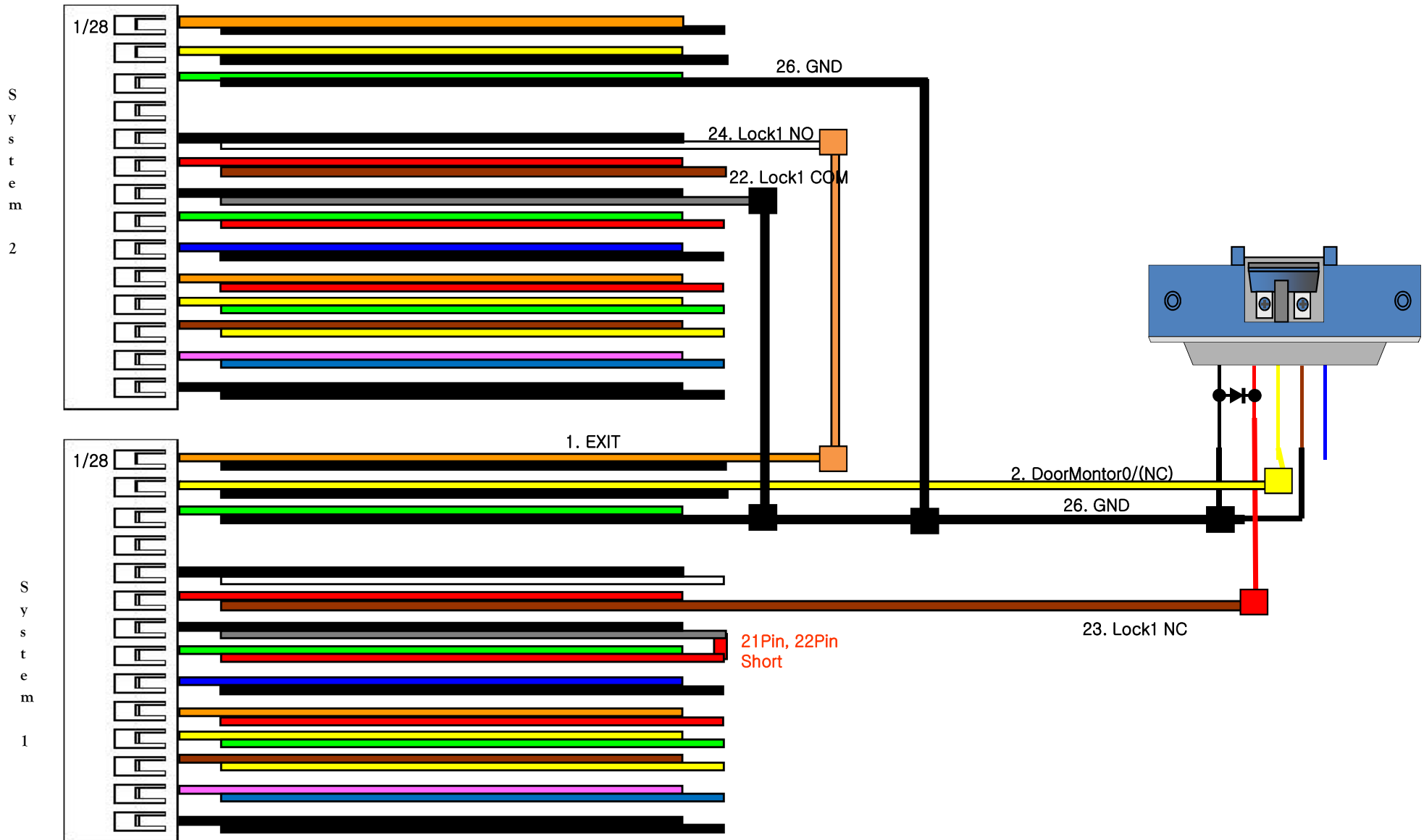

5. Connecting Strike Type Door Lock (Fail Secure)

5.1. Connecting One System/ One Lock

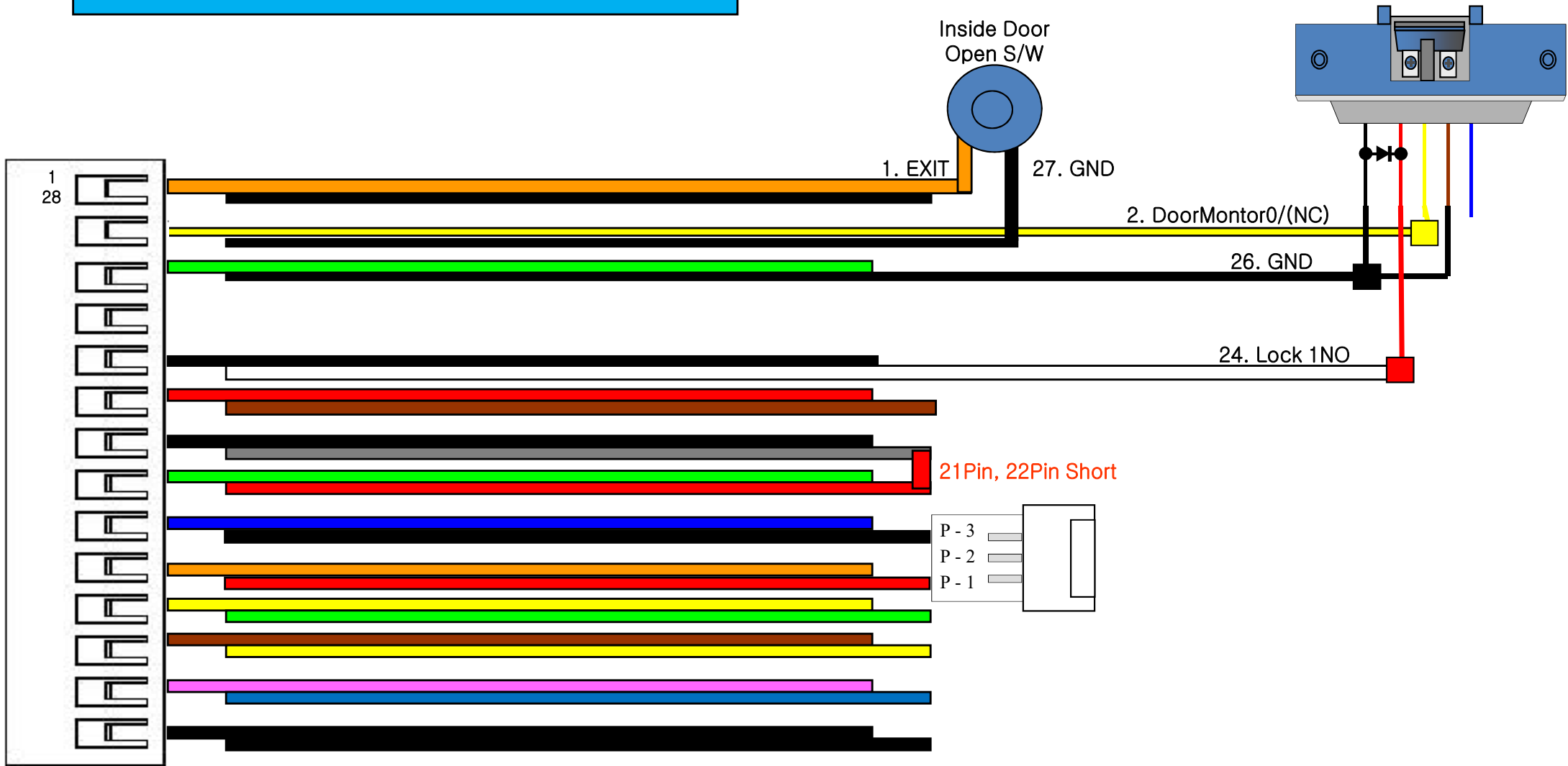

5. Connecting Strike Type Door Lock (Fail Secure)

5.2. Connecting Two Systems/ One Lock

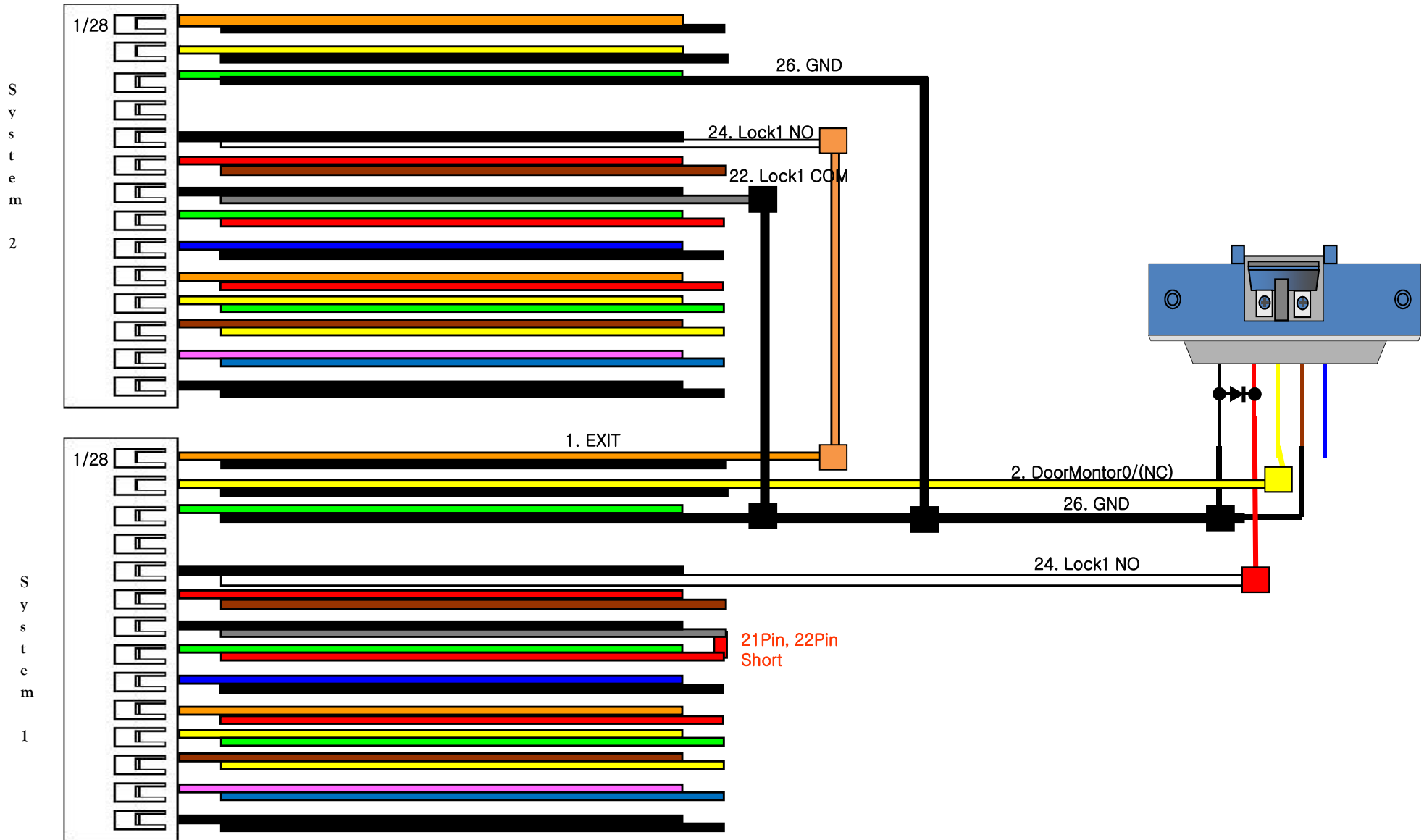

6. Connecting an EM Type Door Lock (Fail Safe)

6.1. Connecting One System/ One Lock

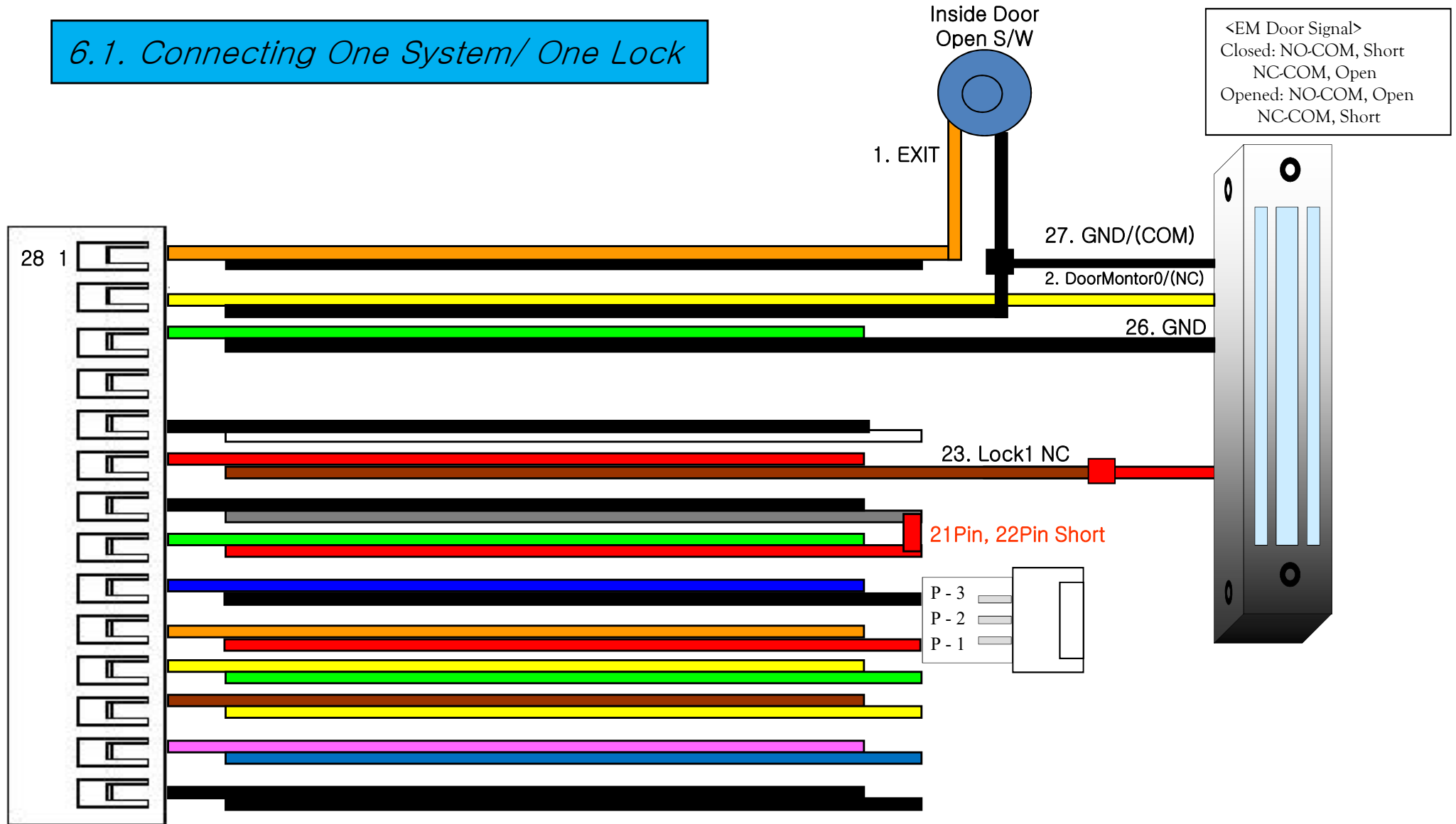

6. Connecting an EM Type Door Lock (Fail Safe)

6.2. Connecting Two Systems/ One Lock

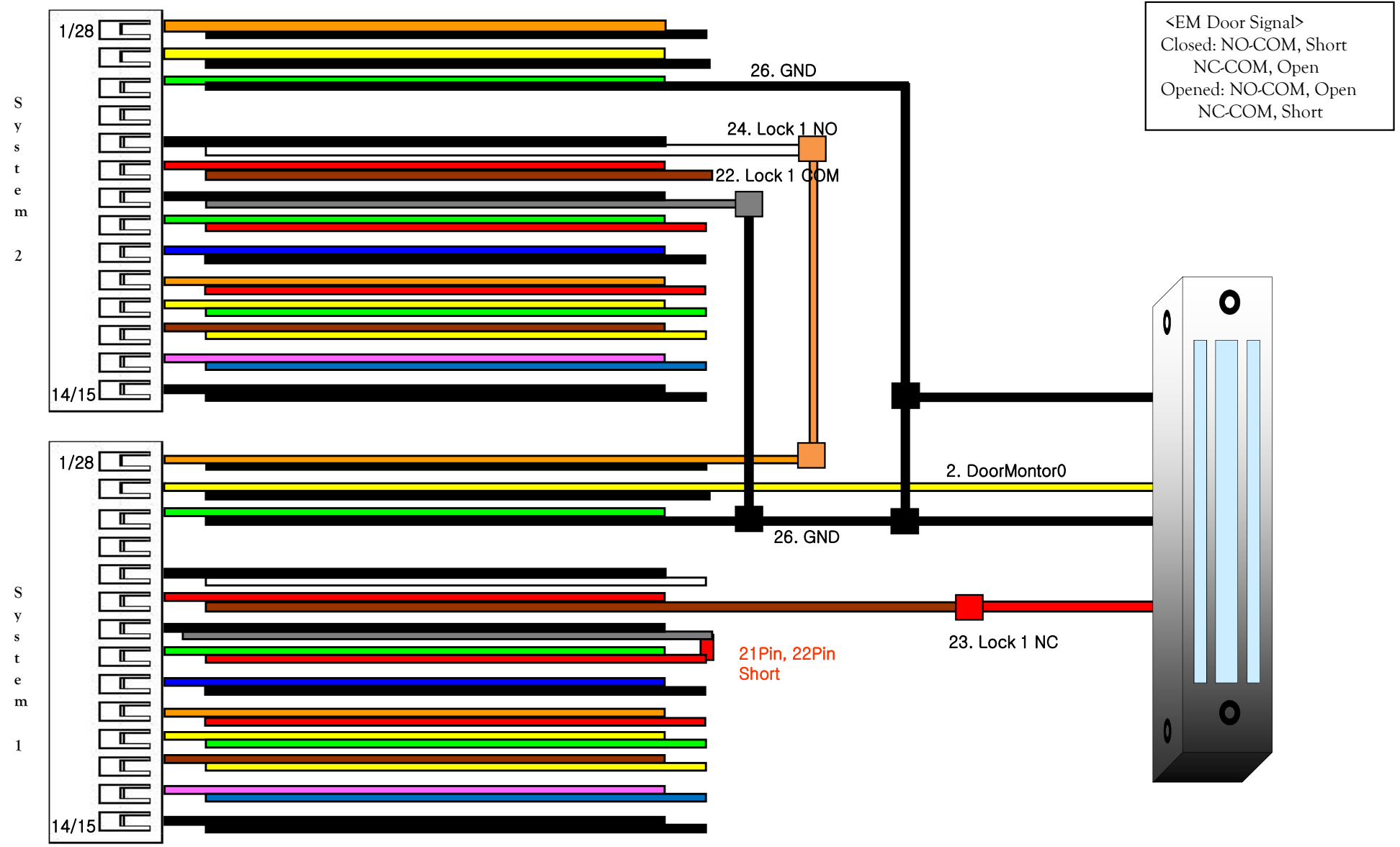

6. Connecting an EM Type Door Lock (Fail Safe)

6.3. Connecting One System/ Two Locks "Use external DC Power adapter"

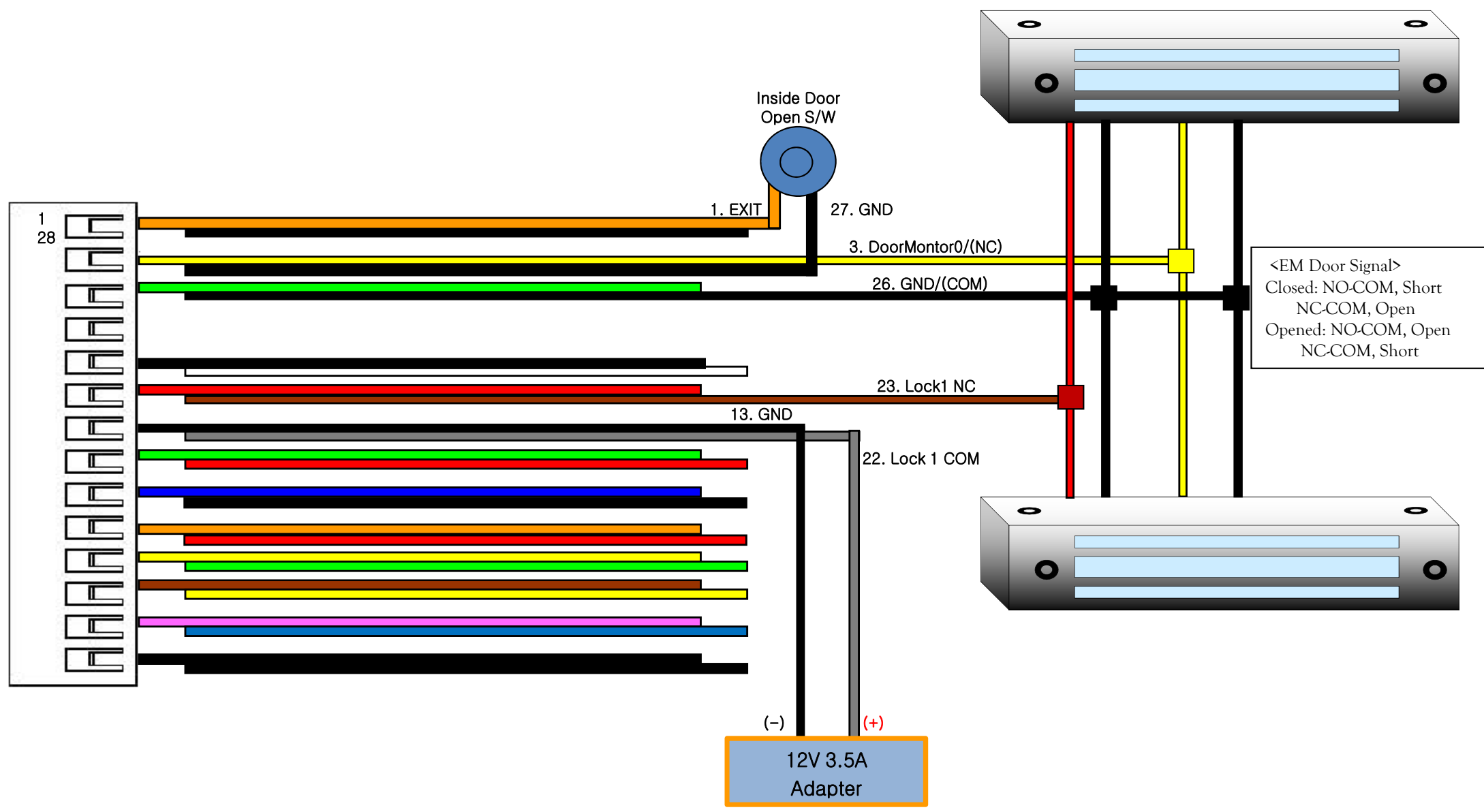

7. Connecting Auto-Door (Contact Control)

7.1. Connecting One System/ One Door

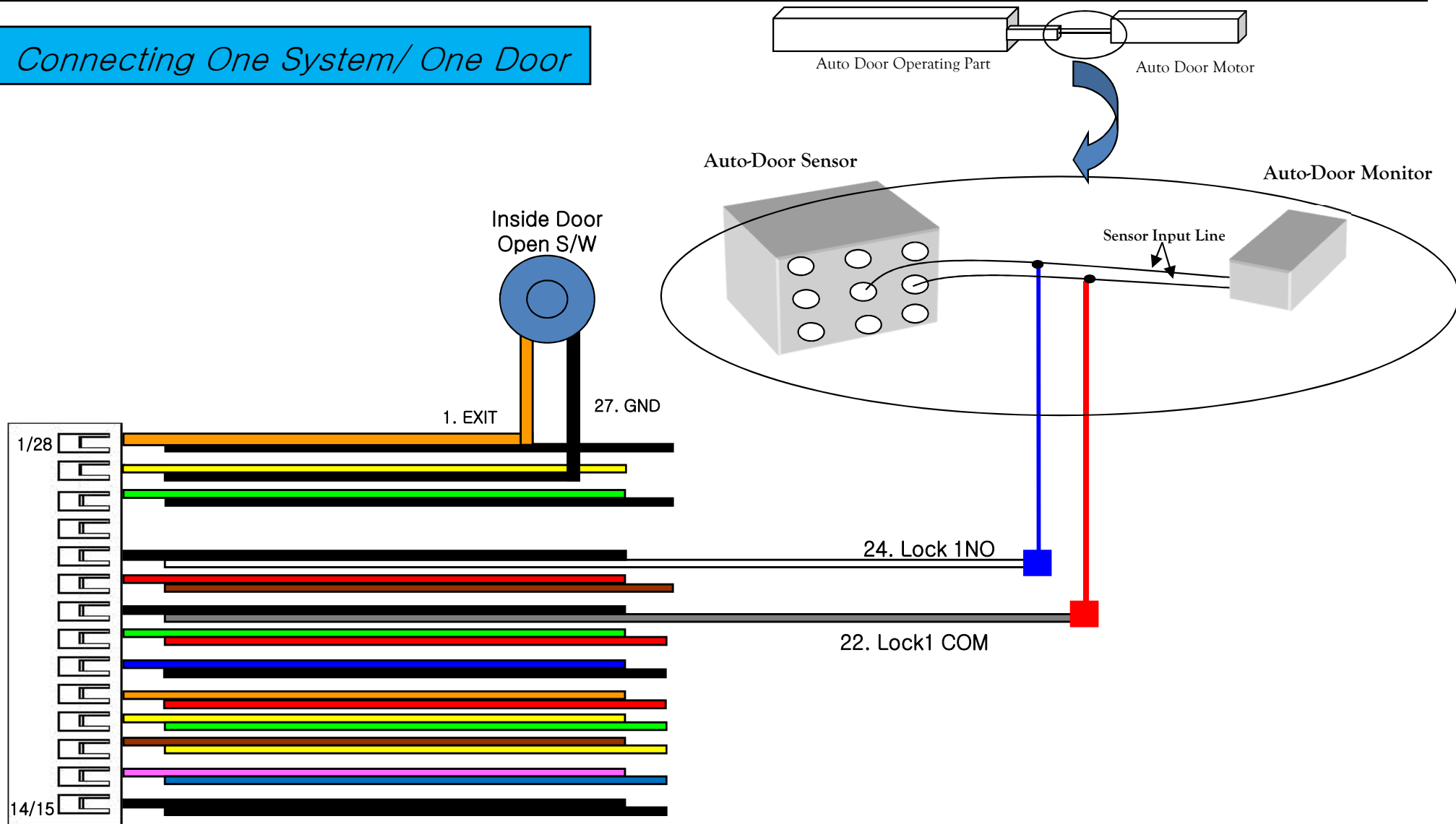

8. Connecting Auto-Door (Contact Control)

7.2. Connecting Two Systems/ One Lock

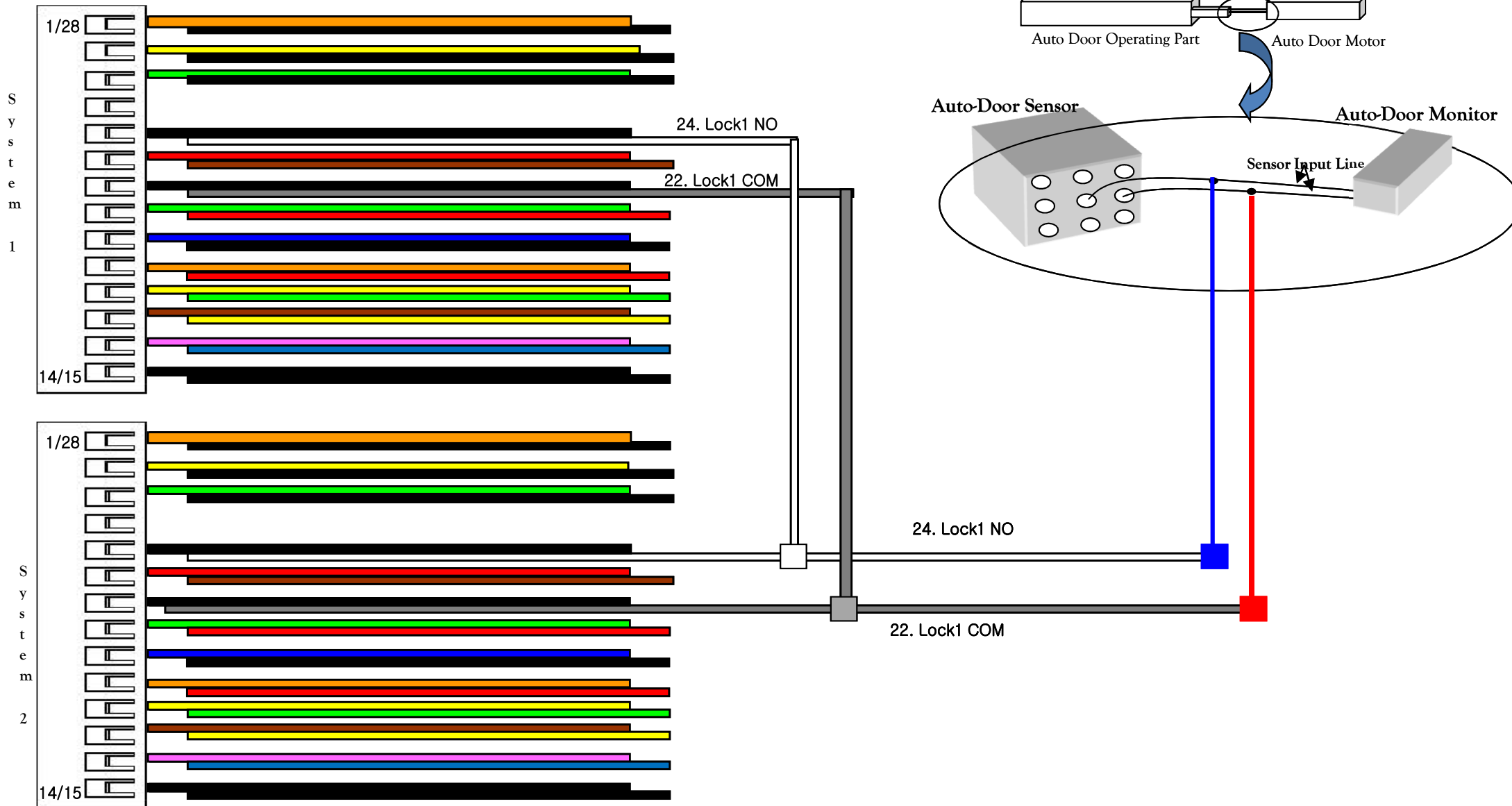

9. Connecting Wiegand IN/OUT to External Controller

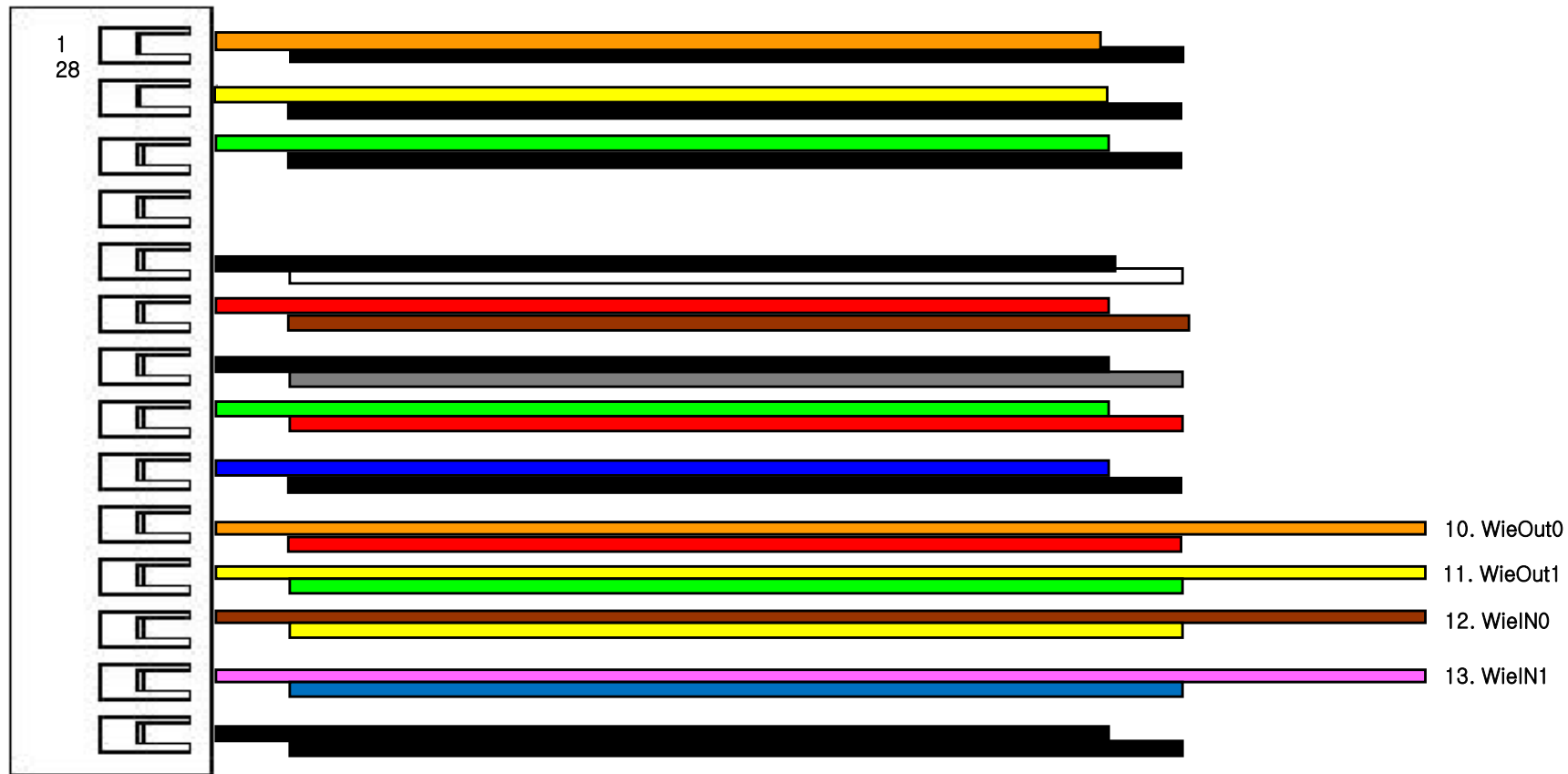

10. Appendix

10.1 How to connect the VS-R20D RF Dummy Card Reader

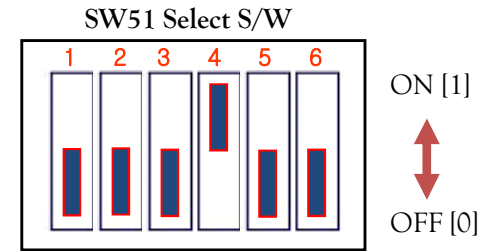

- * 1, 2, 3 OFF: 26Bit
- * 4 ON: Wiegand Mode

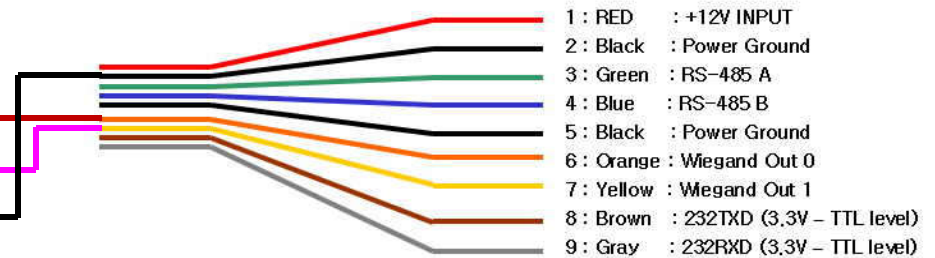

10. Appendix

10.2 How to connect the VS-R20D SC Dummy Card Reader

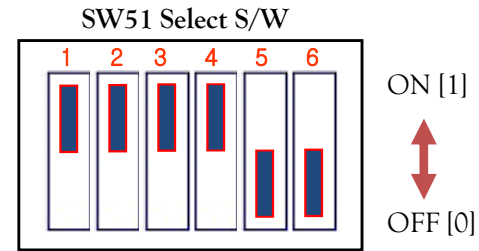

- * 1, 2, 3 ON: 34Bit
- * 4 ON: Wiegand Mode

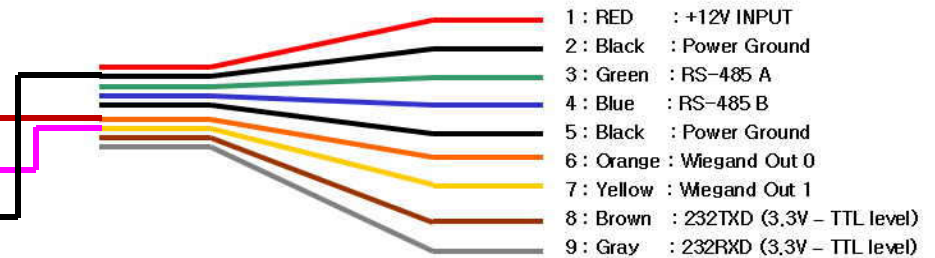

11. Resistor Setting for RS485 End Termination

11.1 RS-485 Setting : Default Setting is off.

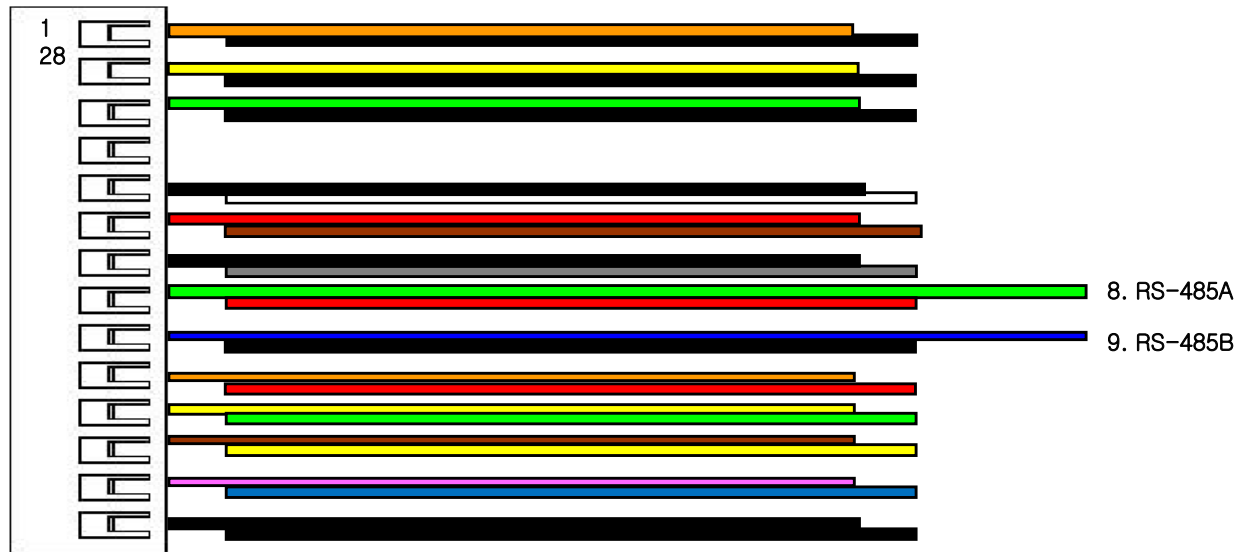

11.2 RS-485 Setting : ON: 120 Ohm Resistor is connected between 485A and 485B

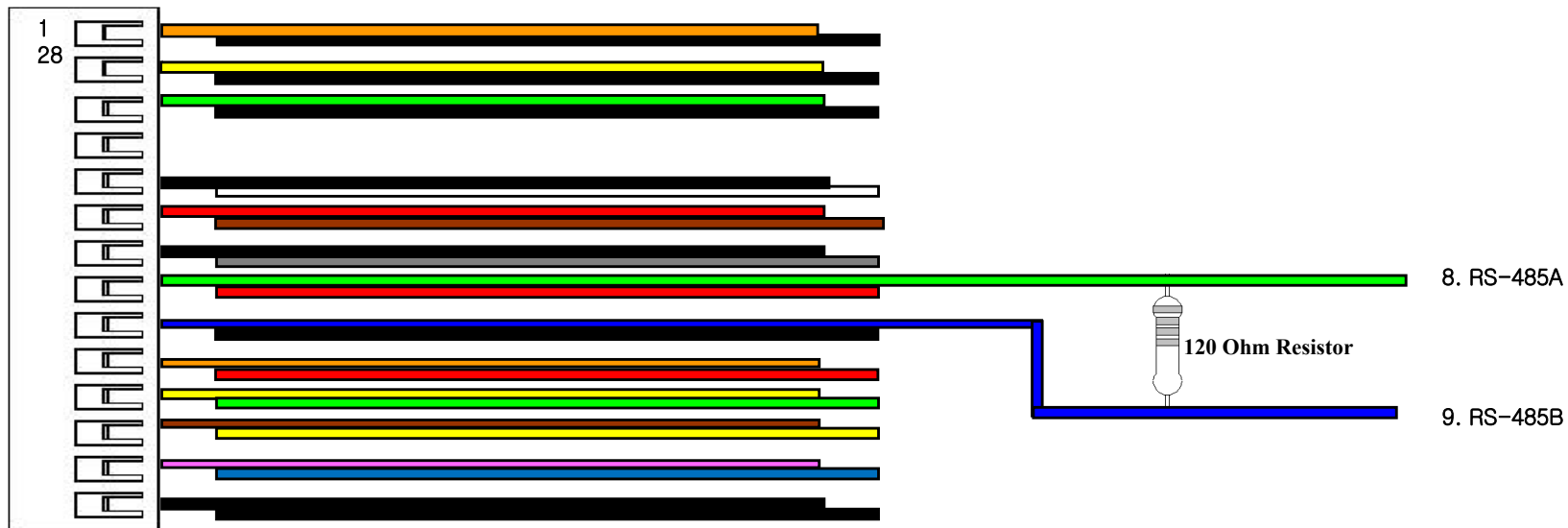

12. Appendix

12. How to connect an external relay

** It is recommended to connect an external relay if a problem occurs after connection with an external equipment such as a speed gate.

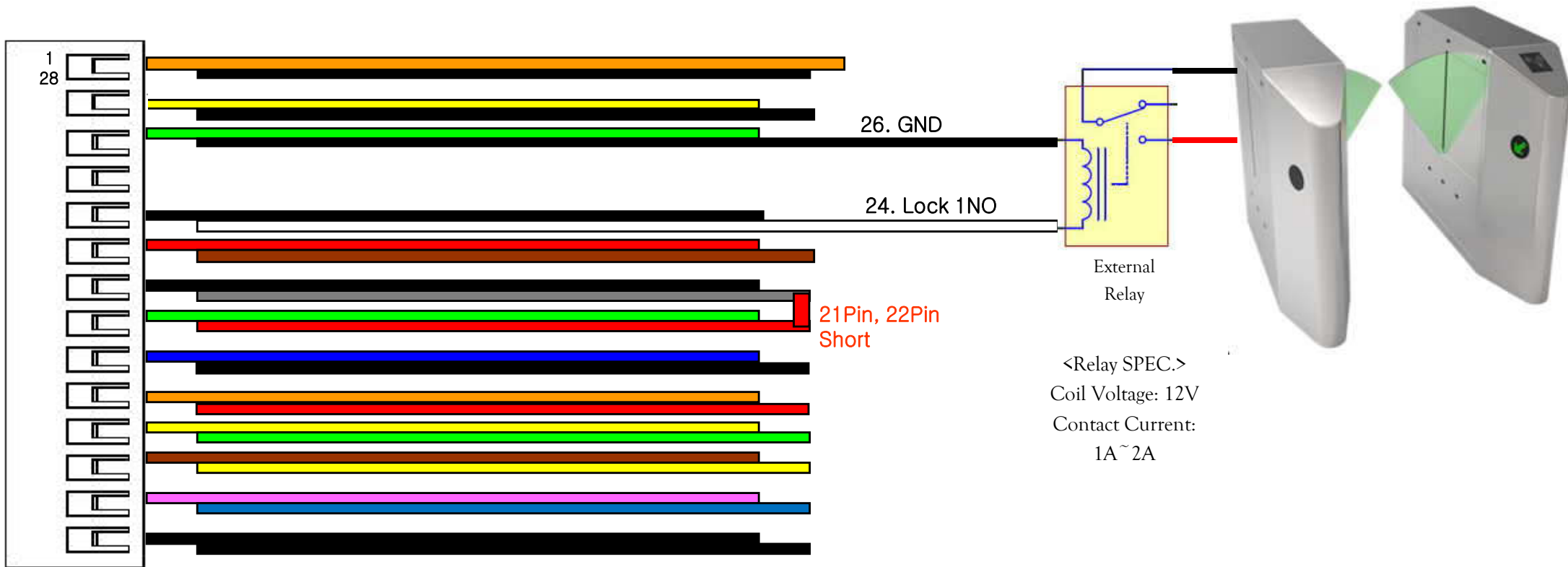

13. Wiring Guide

13.1 Terminal & Exit Button

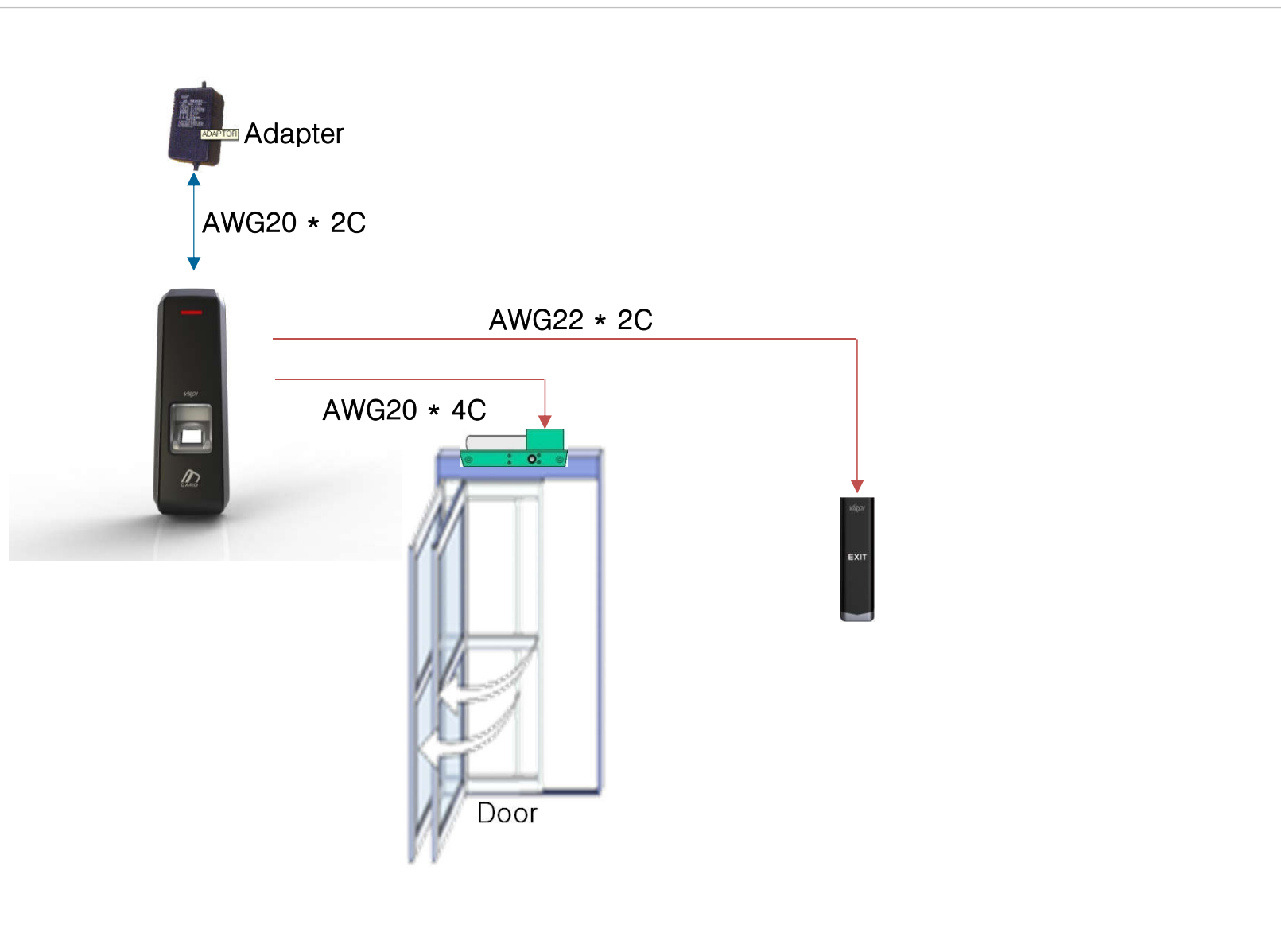

13. Wiring Guide

13.2 Terminal & Exit Button

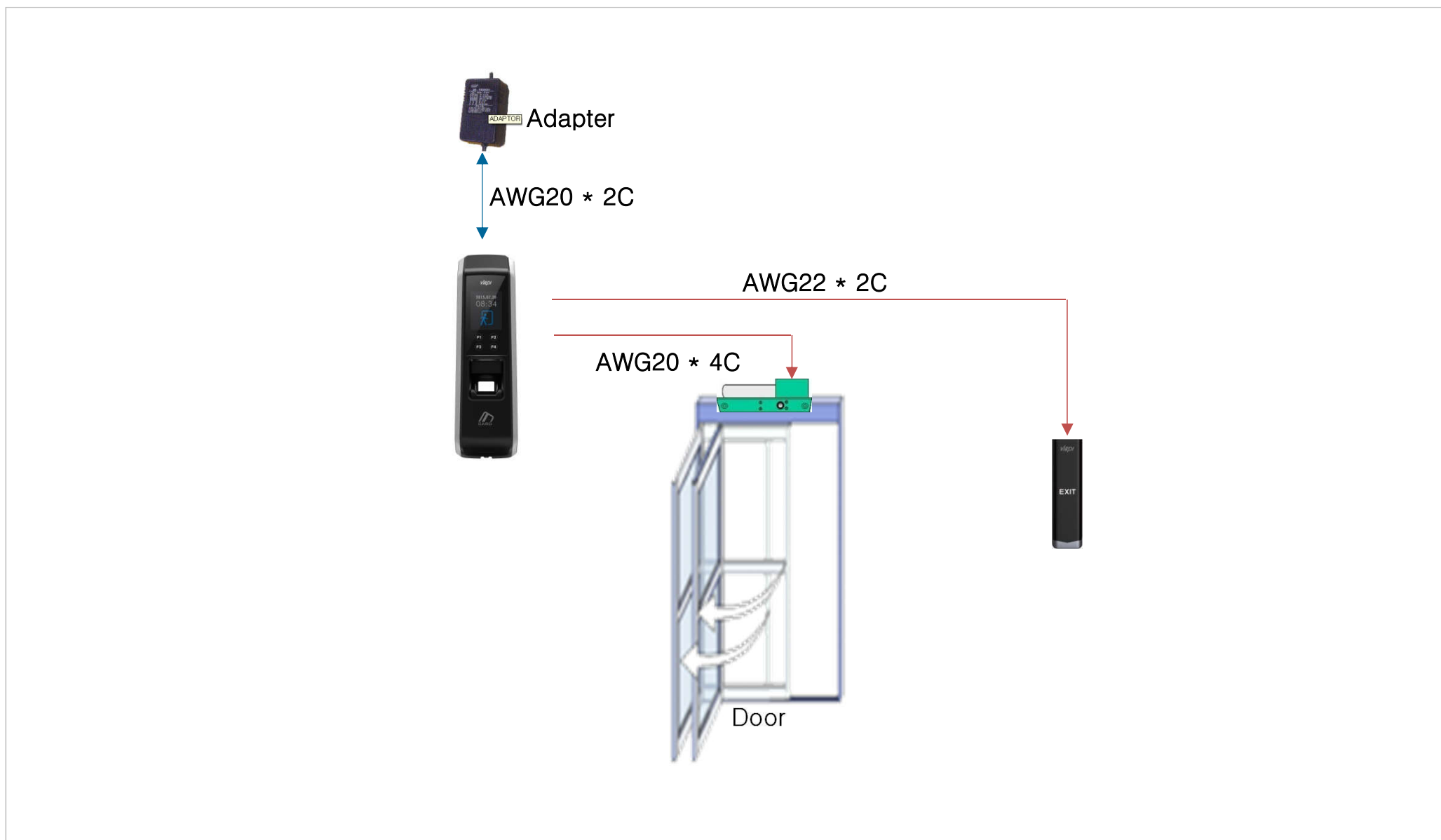

13. Wiring Guide

13.3 Terminal & Exit Button

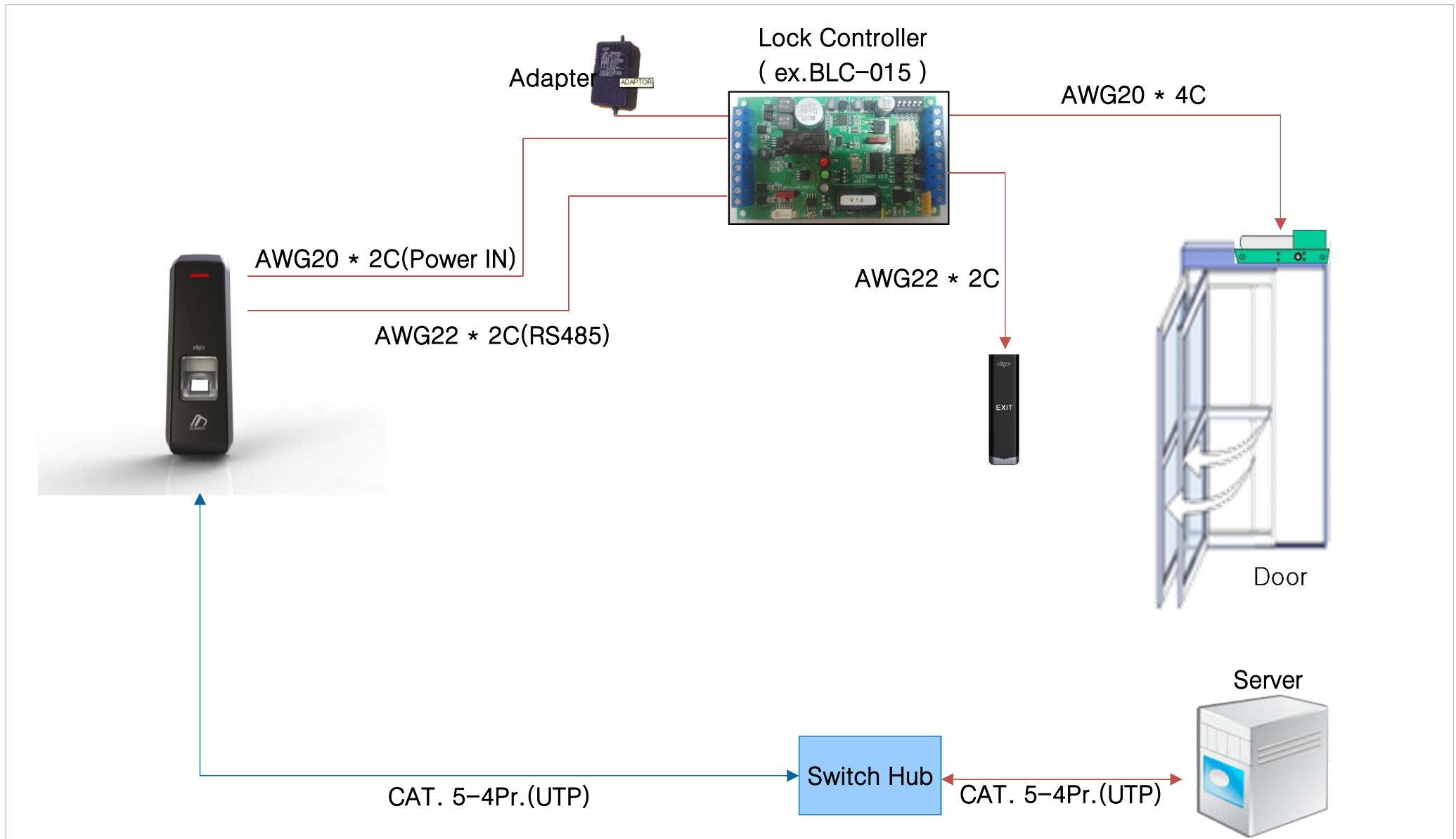

13. Wiring Guide

13.4 Terminal & Exit Button

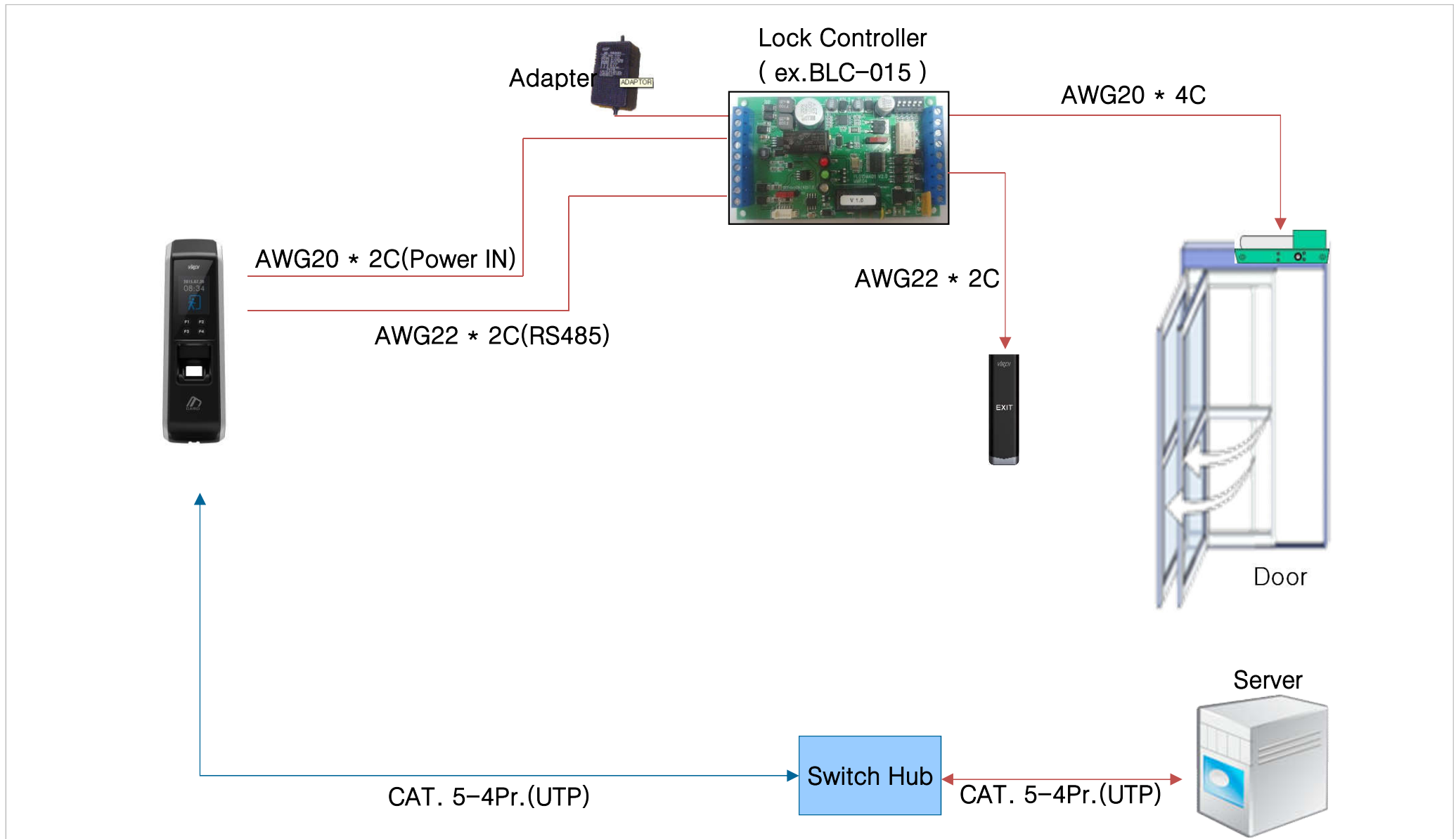

Distributed by



Trading Address: Unit A8 Caxton Point Business Centre, Caxton Point, Caxton Way, Stevenage, SG1 2XU, UK
Registered Office: c/o Becktech Limited, Terminus Road, Chichester, Sussex, PO19 8DW, UK
Telephone: +44 (0)1707 330 541 | Email: sales@genieproducts.co.uk